

# 108 dB, 192 kHz 4-In, 6-Out TDM CODEC

## FEATURES

- ◆ Four 24-bit A/D, Six 24-bit D/A Converters
- ◆ ADC Dynamic Range
  - 105 dB Differential
  - 102 dB Single-Ended
- ◆ DAC Dynamic Range
  - 108 dB Differential
  - 105 dB Single-Ended
- ◆ ADC/DAC THD+N
  - -98 dB Differential
  - -95 dB Single-Ended
- ◆ Compatible with Industry-Standard Time Division Multiplexed (TDM) Serial Interface
- ◆ DAC Sampling Rates up to 192 kHz
- ◆ ADC Sampling Rates up to 96 kHz
- ◆ Programmable ADC High-Pass Filter for DC Offset Calibration
- ◆ Logarithmic Digital Volume Control
- ◆ Hardware Mode or Software I<sup>2</sup>C™ & SPI™
- ◆ Supports Logic Levels Between 5 V and 1.8 V

## GENERAL DESCRIPTION

The CS42432 CODEC provides four multi-bit analog-to-digital and six multi-bit digital-to-analog delta-sigma converters. The CODEC is capable of operation with either differential or single-ended inputs and outputs, in a 52-pin MQFP package.

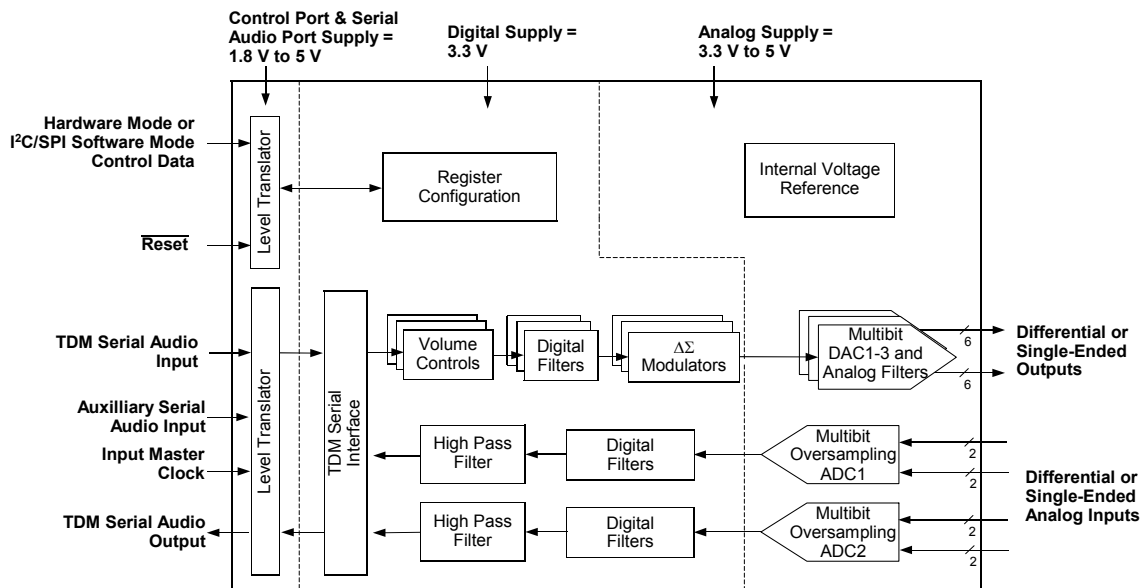
Four fully differential, or single-ended, inputs are available on stereo ADC1 and ADC2. Digital volume control is provided for each ADC channel, with selectable overflow detection.

All six DAC channels provide digital volume control and can operate with differential or single-ended outputs.

An auxiliary serial input is available for an additional two channels of PCM data.

The CS42432 is available in a 52-pin MQFP package in Commercial (-10°C to +70°C) and Automotive (-40°C to +105°C) grades. The CDB42438 Customer Demonstration Board is also available for device evaluation and implementation suggestions. Please refer to [“Ordering Information” on page 58](#) for complete ordering information.

The CS42432 is ideal for audio systems requiring wide dynamic range, negligible distortion and low noise, such as A/V receivers, DVD receivers, and automotive audio systems.



---

**TABLE OF CONTENTS**

|   |           |
|---|-----------|
| <b>1. PIN DESCRIPTIONS - SOFTWARE MODE .....</b>                      | <b>6</b>  |
| 1.1 Digital I/O Pin Characteristics .....                             | 8         |
| <b>2. PIN DESCRIPTIONS - HARDWARE MODE .....</b>                      | <b>9</b>  |
| <b>3. TYPICAL CONNECTION DIAGRAMS .....</b>                           | <b>11</b> |
| <b>4. CHARACTERISTICS AND SPECIFICATIONS .....</b>                    | <b>13</b> |
| RECOMMENDED OPERATING CONDITIONS .....                                | 13        |
| ABSOLUTE MAXIMUM RATINGS .....  | 13        |
| ANALOG INPUT CHARACTERISTICS (COMMERCIAL) .....                       | 14        |
| ANALOG INPUT CHARACTERISTICS (AUTOMOTIVE) .....                       | 15        |
| ADC DIGITAL FILTER CHARACTERISTICS .....                              | 16        |
| ANALOG OUTPUT CHARACTERISTICS (COMMERCIAL) .....                      | 17        |
| ANALOG OUTPUT CHARACTERISTICS (AUTOMOTIVE) .....                      | 18        |
| COMBINED DAC INTERPOLATION & ON-CHIP ANALOG FILTER RESPONSE .....     | 20        |
| SWITCHING SPECIFICATIONS - ADC/DAC PORT .....                         | 21        |
| SWITCHING CHARACTERISTICS - AUX PORT .....                            | 22        |
| SWITCHING SPECIFICATIONS - CONTROL PORT - I <sup>2</sup> C MODE ..... | 23        |
| SWITCHING SPECIFICATIONS - CONTROL PORT - SPI FORMAT .....            | 24        |
| DC ELECTRICAL CHARACTERISTICS .....                                   | 25        |
| DIGITAL INTERFACE SPECIFICATIONS & CHARACTERISTICS .....              | 25        |
| <b>5. APPLICATIONS .....</b>  | <b>26</b> |
| 5.1 Overview .....  | 26        |
| 5.2 Analog Inputs .....   | 27        |
| 5.2.1 Line-Level Inputs .....   | 27        |
| 5.2.1.1 Hardware Mode .....   | 27        |
| 5.2.1.2 Software Mode .....   | 27        |
| 5.2.2 High-Pass Filter and DC Offset Calibration .....                | 27        |
| 5.2.2.1 Hardware Mode .....   | 28        |
| 5.2.2.2 Software Mode .....   | 28        |
| 5.3 Analog Outputs .....  | 28        |
| 5.3.1 Initialization .....  | 28        |
| 5.3.2 Line-Level Outputs and Filtering .....                          | 28        |
| 5.3.3 Digital Volume Control .....                                    | 30        |
| 5.3.3.1 Hardware Mode .....   | 30        |
| 5.3.3.2 Software Mode .....   | 30        |
| 5.3.4 De-Emphasis Filter .....  | 30        |
| 5.4 System Clocking .....   | 31        |
| 5.4.1 Hardware Mode .....   | 31        |
| 5.4.2 Software Mode .....   | 31        |
| 5.5 CODEC Digital Interface .....                                     | 31        |
| 5.5.1 TDM .....   | 31        |
| 5.5.2 I/O Channel Allocation .....                                    | 32        |
| 5.6 AUX Port Digital Interface Formats .....                          | 32        |
| 5.6.1 Hardware Mode .....   | 32        |
| 5.6.2 Software Mode .....   | 32        |
| 5.6.3 I <sup>2</sup> S .....  | 32        |
| 5.6.4 Left-Justified .....  | 33        |
| 5.7 Control Port Description and Timing .....                         | 33        |
| 5.7.1 SPI Mode .....  | 33        |
| 5.7.2 I <sup>2</sup> C Mode .....                                     | 34        |
| 5.8 Recommended Power-Up Sequence .....                               | 35        |
| 5.8.1 Hardware Mode .....   | 35        |
| 5.8.2 Software Mode .....   | 36        |

|   |           |
|---|-----------|
| 5.9 Reset and Power-Up .....  | 36        |
| 5.10 Power Supply, Grounding, and PCB Layout .....                        | 36        |
| <b>6. REGISTER QUICK REFERENCE .....</b>                                  | <b>37</b> |
| <b>7. REGISTER DESCRIPTION .....</b>                                      | <b>39</b> |
| 7.1 Memory Address Pointer (MAP) .....                                    | 39        |
| 7.1.1 Increment (INCR) .....  | 39        |
| 7.1.2 Memory Address Pointer (MAP[6:0]) .....                             | 39        |
| 7.2 Chip I.D. and Revision Register (Address 01h) (Read Only) .....       | 39        |
| 7.2.1 Chip I.D. (CHIP_ID[3:0]) .....                                      | 39        |
| 7.2.2 Chip Revision (REV_ID[3:0]) .....                                   | 39        |
| 7.3 Power Control (Address 02h) .....                                     | 40        |
| 7.3.1 Power Down ADC Pairs (PDN_ADCX) .....                               | 40        |
| 7.3.2 Power Down DAC Pairs (PDN_DACX) .....                               | 40        |
| 7.3.3 Power Down (PDN) .....  | 40        |
| 7.4 Functional Mode (Address 03h) .....                                   | 41        |
| 7.4.1 MCLK Frequency (MFREQ[2:0]) .....                                   | 41        |
| 7.5 Miscellaneous Control (Address 04h) .....                             | 41        |
| 7.5.1 Freeze Controls (FREEZE) .....                                      | 41        |
| 7.5.2 Auxiliary Digital Interface Format (AUX_DIF) .....                  | 41        |
| 7.6 ADC Control & DAC De-Emphasis (Address 05h) .....                     | 42        |
| 7.6.1 ADC1-2 High-Pass Filter Freeze (ADC1-2_HPF FREEZE) .....            | 42        |
| 7.6.2 DAC De-Emphasis Control (DAC_DEM) .....                             | 42        |
| 7.6.3 ADC1 Single-Ended Mode (ADC1 SINGLE) .....                          | 42        |
| 7.6.4 ADC2 Single-Ended Mode (ADC2 SINGLE) .....                          | 43        |
| 7.7 Transition Control (Address 06h) .....                                | 43        |
| 7.7.1 Single Volume Control (DAC_SNGVOL, ADC_SNGVOL) .....                | 43        |
| 7.7.2 Soft Ramp and Zero Cross Control (ADC_SZC[1:0], DAC_SZC[1:0]) ..... | 43        |
| 7.7.3 Auto-Mute (AMUTE) .....   | 44        |
| 7.7.4 Mute ADC Serial Port (MUTE_ADC_SP) .....                            | 44        |
| 7.8 DAC Channel Mute (Address 07h) .....                                  | 44        |
| 7.8.1 Independent Channel Mute (AOUTX_MUTE) .....                         | 44        |
| 7.9 AOUTX Volume Control (Addresses 08h-0D) .....                         | 45        |
| 7.9.1 Volume Control (AOUTX_VOL[7:0]) .....                               | 45        |
| 7.10 DAC Channel Invert (Address 10h) .....                               | 45        |
| 7.10.1 Invert Signal Polarity (INV_AOUTX) .....                           | 45        |
| 7.11 AINX Volume Control (Address 11h-14h) .....                          | 45        |
| 7.11.1 AINX Volume Control (AINX_VOL[7:0]) .....                          | 45        |
| 7.12 ADC Channel Invert (Address 17h) .....                               | 46        |
| 7.12.1 Invert Signal Polarity (INV_AINX) .....                            | 46        |
| 7.13 Status (Address 19h) (Read Only) .....                               | 46        |
| 7.13.1 Clock Error (CLK_ERROR) .....                                      | 46        |
| 7.13.2 ADC Overflow (ADCX_OVFL) .....                                     | 46        |
| 7.14 Status Mask (Address 1Ah) .....                                      | 47        |
| <b>8. EXTERNAL FILTERS .....</b>  | <b>48</b> |
| 8.1 ADC Input Filter .....  | 48        |
| 8.1.1 Passive Input Filter .....  | 49        |
| 8.1.2 Passive Input Filter w/Attenuation .....                            | 49        |
| 8.2 DAC Output Filter .....   | 50        |
| <b>9. ADC FILTER PLOTS .....</b>  | <b>51</b> |
| <b>10. DAC FILTER PLOTS .....</b>   | <b>53</b> |
| <b>11. PARAMETER DEFINITIONS .....</b>                                    | <b>55</b> |
| <b>12. REFERENCES .....</b>   | <b>56</b> |

|                                       |           |
|---------------------------------------|-----------|
| <b>13. PACKAGE INFORMATION</b> .....  | <b>57</b> |
| 13.1 Thermal Characteristics .....    | 57        |
| <b>14. ORDERING INFORMATION</b> ..... | <b>58</b> |
| <b>15. REVISION HISTORY</b> .....     | <b>58</b> |

## LIST OF FIGURES

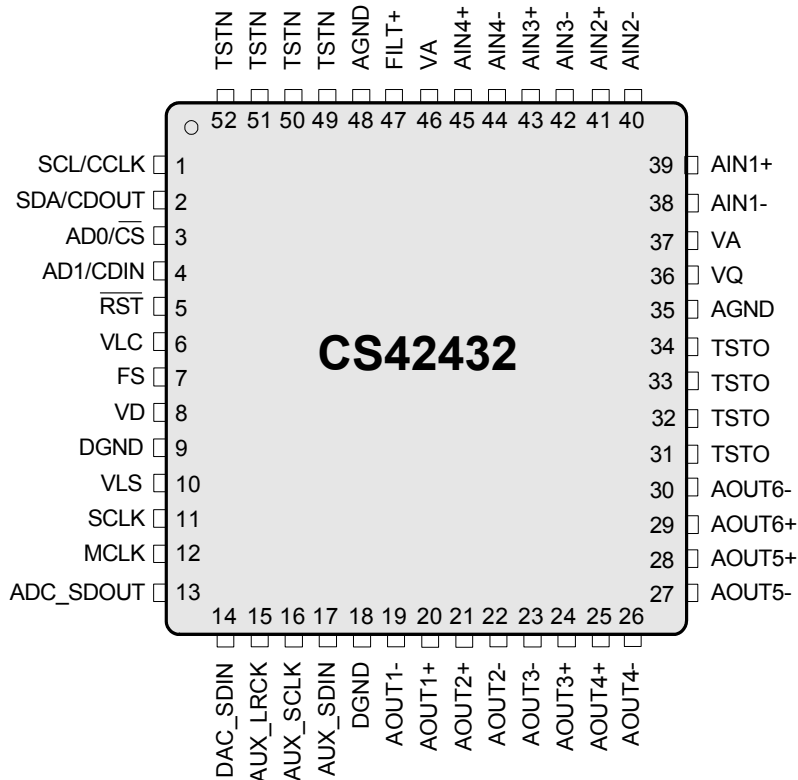
|   |    |
|---|----|
| Figure 1. Typical Connection Diagram (Software Mode) .....    | 11 |
| Figure 2. Typical Connection Diagram (Hardware Mode) .....    | 12 |
| Figure 3. Output Test Load .....                              | 19 |
| Figure 4. Maximum Loading .....                               | 19 |
| Figure 5. TDM Serial Audio Interface Timing .....             | 21 |
| Figure 6. Serial Audio Interface Slave Mode Timing .....      | 22 |
| Figure 7. Control Port Timing - I <sup>2</sup> C Format ..... | 23 |
| Figure 8. Control Port Timing - SPI Format .....              | 24 |
| Figure 9. Full-Scale Input .....                              | 27 |
| Figure 10. Audio Output Initialization Flow Chart .....       | 29 |
| Figure 11. Full-Scale Output .....                            | 30 |
| Figure 12. De-Emphasis Curve .....                            | 31 |
| Figure 13. TDM Serial Audio Format .....                      | 32 |
| Figure 14. AUX I <sup>2</sup> S Format .....                  | 32 |
| Figure 15. AUX Left-Justified Format .....                    | 33 |
| Figure 16. Control Port Timing in SPI Mode .....              | 34 |
| Figure 17. Control Port Timing, I <sup>2</sup> C Write .....  | 34 |
| Figure 18. Control Port Timing, I <sup>2</sup> C Read .....   | 35 |
| Figure 19. Single-to-Differential Active Input Filter .....   | 48 |
| Figure 20. Single-Ended Active Input Filter .....             | 48 |
| Figure 21. Passive Input Filter .....                         | 49 |
| Figure 22. Passive Input Filter w/Attenuation .....           | 49 |
| Figure 23. Active Analog Output Filter .....                  | 50 |
| Figure 24. Passive Analog Output Filter .....                 | 50 |
| Figure 25. SSM Stopband Rejection .....                       | 51 |
| Figure 26. SSM Transition Band .....                          | 51 |
| Figure 27. SSM Transition Band (Detail) .....                 | 51 |
| Figure 28. SSM Passband Ripple .....                          | 51 |
| Figure 29. DSM Stopband Rejection .....                       | 51 |
| Figure 30. DSM Transition Band .....                          | 51 |
| Figure 31. DSM Transition Band (Detail) .....                 | 52 |
| Figure 32. DSM Passband Ripple .....                          | 52 |
| Figure 33. SSM Stopband Rejection .....                       | 53 |
| Figure 34. SSM Transition Band .....                          | 53 |
| Figure 35. SSM Transition Band (detail) .....                 | 53 |
| Figure 36. SSM Passband Ripple .....                          | 53 |
| Figure 37. DSM Stopband Rejection .....                       | 53 |
| Figure 38. DSM Transition Band .....                          | 53 |
| Figure 39. DSM Transition Band (detail) .....                 | 54 |
| Figure 40. DSM Passband Ripple .....                          | 54 |
| Figure 41. QSM Stopband Rejection .....                       | 54 |
| Figure 42. QSM Transition Band .....                          | 54 |
| Figure 43. QSM Transition Band (detail) .....                 | 54 |
| Figure 44. QSM Passband Ripple .....                          | 54 |

---

**LIST OF TABLES**

|   |    |
|---|----|
| Table 1. I/O Power Rails .....                            | 8  |
| Table 2. Hardware Configurable Settings .....             | 26 |
| Table 3. MCLK Frequency Settings .....                    | 31 |
| Table 4. Serial Audio Interface Channel Allocations ..... | 32 |
| Table 5. MCLK Frequency Settings .....                    | 41 |
| Table 6. Example AOUT Volume Settings .....               | 45 |
| Table 7. Example AIN Volume Settings .....                | 46 |

## 1. PIN DESCRIPTIONS - SOFTWARE MODE



| Pin Name             | #    | Pin Description  |
|----------------------|------|--|
| SCL/CCLK             | 1    | <b>Serial Control Port Clock (Input)</b> - Serial clock for the control port interface.  |
| SDA/CDOUT            | 2    | <b>Serial Control Data I/O (Input/Output)</b> - Input/Output for I <sup>2</sup> C data. Output for SPI data.   |
| AD0/ $\overline{CS}$ | 3    | <b>Address Bit [0]/ Chip Select (Input)</b> - Chip address bit in I <sup>2</sup> C Mode. Control signal used to select the chip in SPI Mode.                       |
| AD1/CDIN             | 4    | <b>Address Bit [1]/ SPI Data Input (Input)</b> - Chip address bit in I <sup>2</sup> C Mode. Input for SPI data.  |
| $\overline{RST}$     | 5    | <b>Reset (Input)</b> - The device enters a low-power mode and all internal registers are reset to their default settings when low.                                 |
| VLC                  | 6    | <b>Control Port Power (Input)</b> - Determines the required signal level for the control port interface. See "Digital I/O Pin Characteristics" on page 8.          |
| FS                   | 7    | <b>Frame Sync (Input)</b> - Signals the start of a new TDM frame in the TDM digital interface format.  |
| VD                   | 8    | <b>Digital Power (Input)</b> - Positive power supply for the digital section.  |
| DGND                 | 9,18 | <b>Digital Ground (Input)</b> - Ground reference for the digital section.  |
| VLS                  | 10   | <b>Serial Port Interface Power (Input)</b> - Determines the required signal level for the serial port interfaces. See "Digital I/O Pin Characteristics" on page 8. |
| SCLK                 | 11   | <b>Serial Clock (Input)</b> - Serial clock for the serial audio interface. Input frequency must be 256 x Fs.   |
| MCLK                 | 12   | <b>Master Clock (Input)</b> - Clock source for the delta-sigma modulators and digital filters.   |
| ADC_SDOUT            | 13   | <b>Serial Audio Data Output (Output)</b> - TDM output for two's complement serial audio data.  |
| DAC_SDIN             | 14   | <b>DAC Serial Audio Data Input (Input)</b> - TDM Input for two's complement serial audio data.   |
| AUX_LRCK             | 15   | <b>Auxiliary Left/Right Clock (Output)</b> - Determines which channel, Left or Right, is currently active on the Auxiliary serial audio data line.                 |

|  |  |   |
|--|--|---|
| AUX_SCLK   | 16   | <b>Auxiliary Serial Clock (Output)</b> - Serial clock for the Auxiliary serial audio interface.   |
| AUX_SDIN   | 17   | <b>Auxiliary Serial Input (Input)</b> - The 42432 provides an additional serial input for two's complement serial audio data.   |
| AOUT1 +,-<br>AOUT2 +,-<br>AOUT3 +,-<br>AOUT4 +,-<br>AOUT5 +,-<br>AOUT6 +,- | 20,19<br>21,22<br>24,23<br>25,26<br>28,27<br>29,30 | <b>Differential Analog Output (Output)</b> - The full-scale differential analog output level is specified in the Analog Characteristics specification table. Each positive leg of the differential outputs may also be used single-ended. |
| TSTO   | 31,32<br>33,34                                     | <b>Test Out</b> - These pins are outputs used for test purposes only. They must not be connected to any external trace or other connection.   |
| TSTN   | 49,50<br>51,52                                     | <b>Test In</b> - These pins are inputs used for test purposes only. They must be tied to ground for normal operation.   |
| AGND   | 35,48  | <b>Analog Ground (Input)</b> - Ground reference for the analog section.   |
| VQ   | 36   | <b>Quiescent Voltage (Output)</b> - Filter connection for internal quiescent reference voltage.   |
| VA   | 37,46  | <b>Analog Power (Input)</b> - Positive power supply for the analog section.   |
| AIN1 +,-<br>AIN2 +,-<br>AIN3 +,-<br>AIN4 +,-                               | 39,38<br>41,40<br>43,42<br>45,44                   | <b>Differential Analog Input (Input)</b> - Signals are presented differentially to the delta-sigma modulators. The full-scale input level is specified in the Analog Characteristics specification table.                                 |
| FILT+  | 47   | <b>Positive Voltage Reference (Output)</b> - Positive reference voltage for the internal sampling circuits.   |

## 1.1 Digital I/O Pin Characteristics

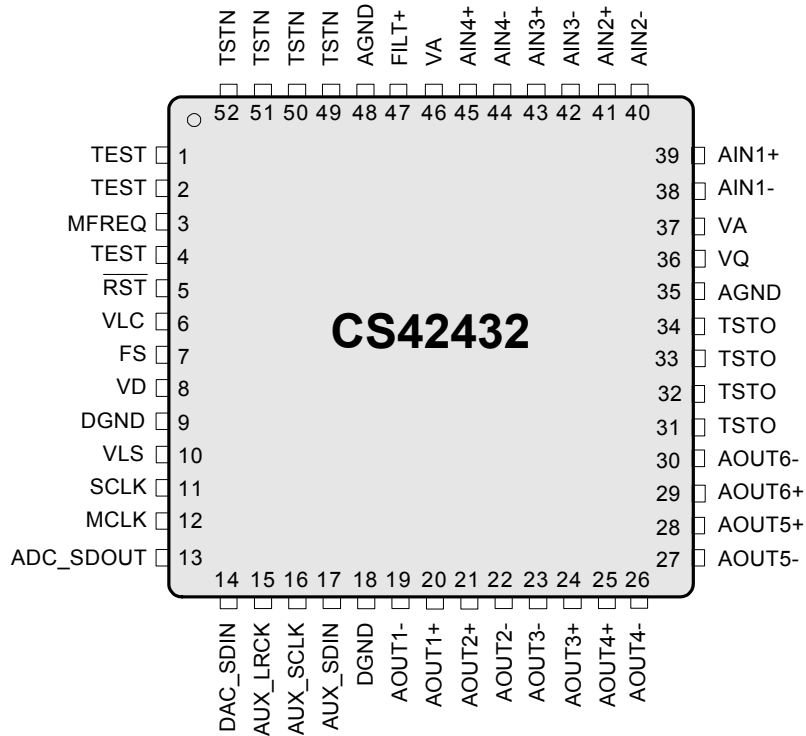
Various pins on the CS42432 are powered from separate power supply rails. The logic level for each input should adhere to the corresponding power rail and should not exceed the maximum ratings.

| Power Rail | Pin Name SW/(HW)        | I/O          | Driver                         | Receiver                             |
|------------|-------------------------|--------------|--------------------------------|--------------------------------------|
| VLC        | $\overline{\text{RST}}$ | Input        | -                              | 1.8 V - 5.0 V, CMOS                  |
|            | SCL/CCLK (TEST)         | Input        | -                              | 1.8 V - 5.0 V, CMOS, with Hysteresis |
|            | SDA/CDOUT (TEST)        | Input/Output | 1.8 V - 5.0 V, CMOS/Open Drain | 1.8 V - 5.0 V, CMOS, with Hysteresis |
|            | AD0/CS (MFREQ)          | Input        | -                              | 1.8 V - 5.0 V, CMOS                  |
|            | AD1/CDIN (TEST)         | Input        | -                              | 1.8 V - 5.0 V, CMOS                  |
| VLS        | MCLK                    | Input        | -                              | 1.8 V - 5.0 V, CMOS                  |
|            | LRCK                    | Input        | -                              | 1.8 V - 5.0 V, CMOS                  |
|            | SCLK                    | Input        | -                              | 1.8 V - 5.0 V, CMOS                  |
|            | ADC_SDOOUT2             | Input/Output | 1.8 V - 5.0 V, CMOS            | -                                    |
|            | DAC_SDIN                | Input        | -                              | 1.8 V - 5.0 V, CMOS                  |
|            | AUX_LRCK                | Output       | 1.8 V - 5.0 V, CMOS            | -                                    |
|            | AUX_SCLK                | Output       | 1.8 V - 5.0 V, CMOS            | -                                    |
|            | AUX_SDIN                | Input        | -                              | 1.8 V - 5.0 V, CMOS                  |

**Table 1. I/O Power Rails**



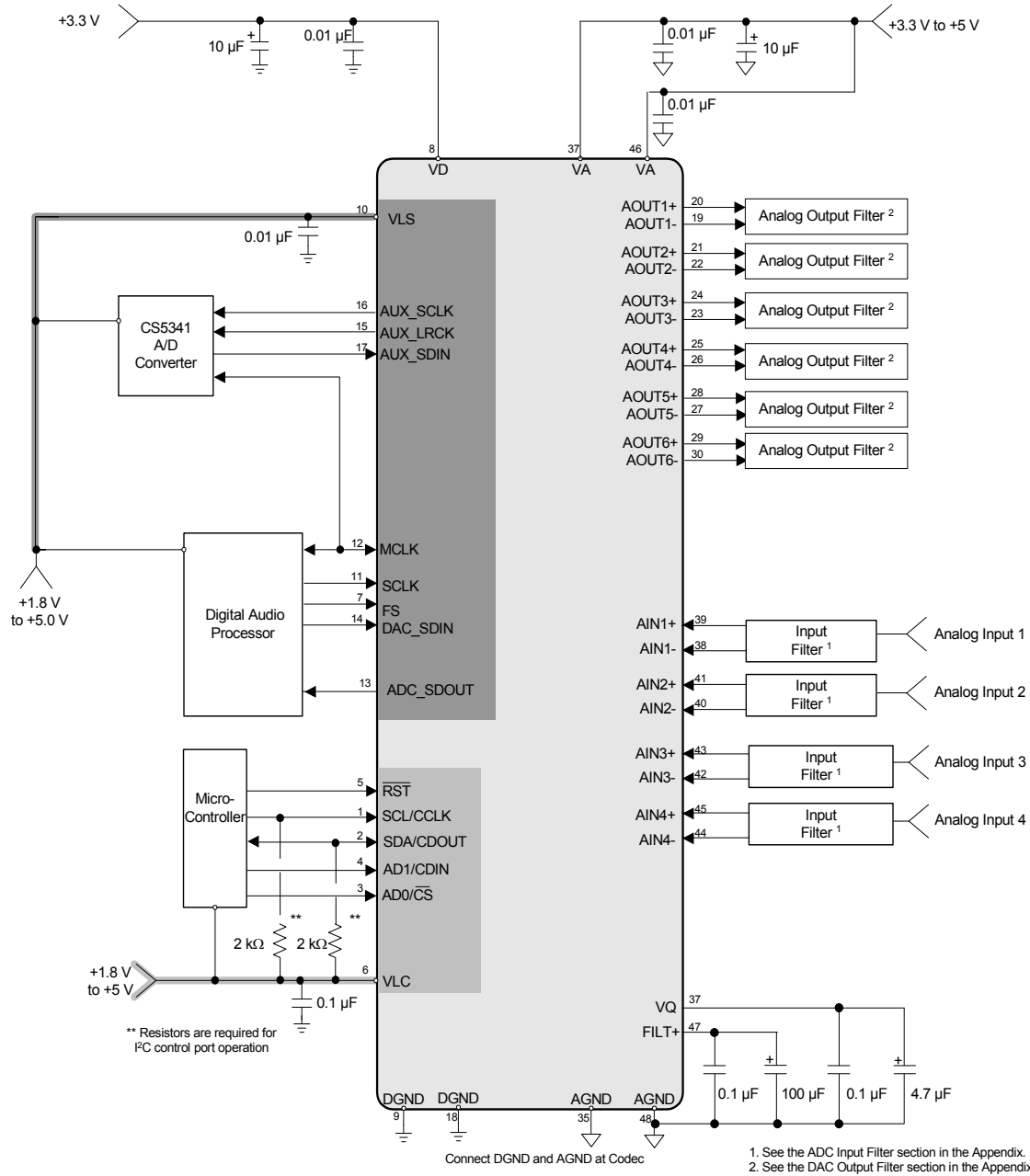
## 2. PIN DESCRIPTIONS - HARDWARE MODE



| Pin Name | #     | Pin Description   |
|----------|-------|---|
| TEST     | 1,2,4 | <b>Test (Input)</b> - Must be tied high or low. Do not leave unconnected.   |
| MFREQ    | 3     | <b>MCLK Frequency (Input)</b> - Sets the required frequency range of the input Master Clock. See section 5.4 for the appropriate settings.                |
| RST      | 5     | <b>Reset (Input)</b> - The device enters a low power mode and all internal registers are reset to their default settings when low.                        |
| VLC      | 6     | <b>Control Port Power (Input)</b> - Determines the required signal level for the control port interface. See "Digital I/O Pin Characteristics" on page 8. |
| FS       | 7     | <b>Frame Sync (Input)</b> - Signals the start of a new TDM frame in the TDM digital interface format.   |
| VD       | 8     | <b>Digital Power (Input)</b> - Positive power supply for the digital section.   |
| VLS      | 10    | <b>Serial Port Interface Power (Input)</b> - Determines the required signal level for the serial port interfaces.   |
| SCLK     | 11    | <b>Serial Clock (Input)</b> - Serial clock for the serial audio interface. Input frequency must be 256xFs.  |
| ADC_SDOU | 13    | <b>Serial Audio Data Output (Output)</b> - TDM output for two's complement serial audio data.   |
| DAC_SDIN | 14    | <b>DAC Serial Audio Data Input (Input)</b> - Input for two's complement serial audio data.  |
| AUX_LRCK | 15    | <b>Auxiliary Left/Right Clock (Output)</b> - Determines which channel, Left or Right, is currently active on the Auxiliary serial audio data line.        |
| AUX_SCLK | 16    | <b>Auxiliary Serial Clock (Output)</b> - Serial clock for the Auxiliary serial audio interface.   |
| AUX_SDIN | 17    | <b>Auxiliary Serial Input (Input)</b> - The 42432 provides an additional serial input for two's complement serial audio data.                             |

|           |                |  |
|-----------|----------------|--|
| AOUT1 +,- | 20,19          | <b>Differential Analog Output (Output)</b> - The full-scale differential analog output level is specified in the Analog Characteristics specification table.<br>Each positive leg of the differential outputs may also be used single-ended. |
| AOUT2 +,- | 21,22          |  |
| AOUT3 +,- | 24,23          |  |
| AOUT4 +,- | 25,26          |  |
| AOUT5 +,- | 28,27          |  |
| AOUT6 +,- | 29,30          |  |
| TSTN      | 49,50<br>51,52 | <b>Test In (Input)</b> - This pin is an input used for test purposes. It must be tied to ground for normal operation.  |
| TSTO      | 31,32<br>33,34 | <b>Test Out (Output)</b> - This pin is an output used for test purposes only. It must not be connected to any external trace or other connection.  |
| AGND      | 35,48          | <b>Analog Ground (Input)</b> -   |
| VQ        | 36             | <b>Quiescent Voltage (Output)</b> - Filter connection for internal quiescent reference voltage.  |
| VA        | 37,46          | <b>Analog Power (Input)</b> - Positive power supply for the analog section.  |
| AIN1 +,-  | 39,38          | <b>Differential Analog Input (Input)</b> - Signals are presented differentially to the delta-sigma modulators. The full-scale input level is specified in the Analog Characteristics specification table.                                    |
| AIN2 +,-  | 41,40          |  |
| AIN3 +,-  | 43,42          |  |
| AIN4 +,-  | 45,44          |  |
| FILT+     | 47             | <b>Positive Voltage Reference (Output)</b> - Positive reference voltage for the internal sampling circuits.  |

### 3. TYPICAL CONNECTION DIAGRAMS



**Figure 1. Typical Connection Diagram (Software Mode)**

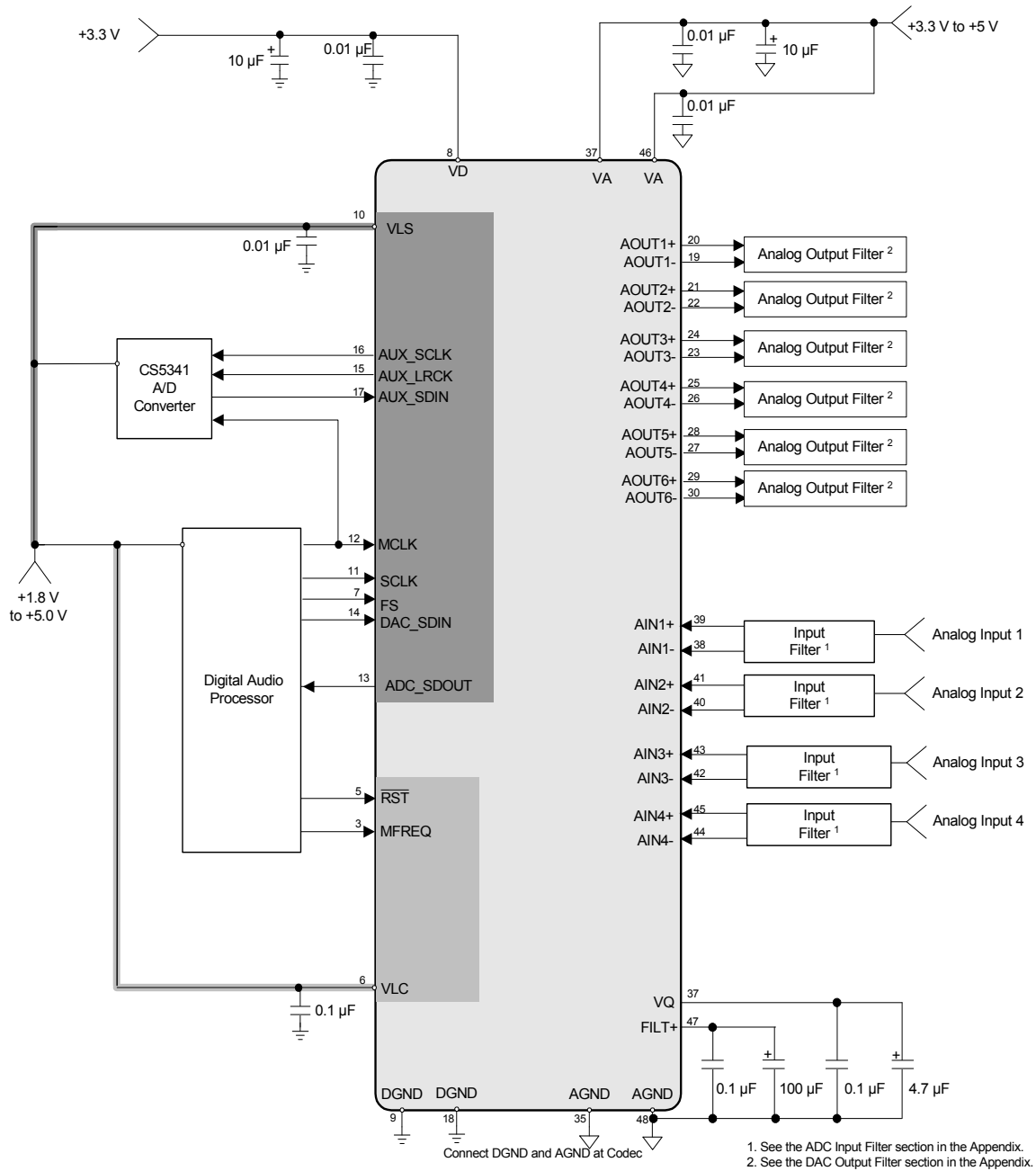


Figure 2. Typical Connection Diagram (Hardware Mode)

## 4. CHARACTERISTICS AND SPECIFICATIONS

### RECOMMENDED OPERATING CONDITIONS

(AGND=DGND=0 V, all voltages with respect to ground.)

| Parameters                      | Symbol         | Min  | Max  | Units |
|---------------------------------|----------------|------|------|-------|
| DC Power Supply                 |                |      |      |       |
| Analog (Note 1)                 | VA             | 3.14 | 5.25 | V     |
| Digital                         | VD             | 3.14 | 3.47 | V     |
| Serial Audio Interface (Note 2) | VLS            | 1.71 | 5.25 | V     |
| Control Port Interface          | VLC            | 1.71 | 5.25 | V     |
| Ambient Temperature             |                |      |      |       |
| Commercial -CMZ                 | T <sub>A</sub> | -10  | +70  | °C    |
| Automotive -DMZ                 |                | -40  | +105 | °C    |

### ABSOLUTE MAXIMUM RATINGS

(AGND = DGND = 0 V; all voltages with respect to ground.)

| Parameters                                    | Symbol                                    | Min      | Max      | Units |
|---|---|----------|----------|-------|
| DC Power Supply                               | Analog VA                                 | -0.3     | 6.0      | V     |
|   | Digital VD                                | -0.3     | 6.0      | V     |
|   | Serial Port Interface VLS                 | -0.3     | 6.0      | V     |
|   | Control Port Interface VLC                | -0.3     | 6.0      | V     |
| Input Current (Note 3)                        | I <sub>in</sub>                           | -        | ±10      | mA    |
| Analog Input Voltage (Note 4)                 | V <sub>IN</sub>                           | AGND-0.7 | VA+0.7   | V     |
| Digital Input Voltage (Note 4)                | Serial Port Interface V <sub>IND-S</sub>  | -0.3     | VLS+ 0.4 | V     |
|   | Control Port Interface V <sub>IND-C</sub> | -0.3     | VLC+ 0.4 | V     |
| Ambient Operating Temperature (power applied) | T <sub>A</sub>                            | -50      | +125     | °C    |
| Storage Temperature                           | T <sub>stg</sub>                          | -65      | +150     | °C    |

**WARNING:** Operation at or beyond these limits may result in permanent damage to the device. Normal operation is not guaranteed at these extremes.

#### Notes:

1. Typical Analog input/output performance will slightly degrade at VA = 3.3 V.
2. The ADC\_SDOOUT may not meet timing requirements in Double-Speed Mode.
3. Any pin except supplies. Transient currents of up to ±100 mA on the analog input pins will not cause SCR latch-up.
4. The maximum over/under voltage is limited by the input current.

**ANALOG INPUT CHARACTERISTICS (COMMERCIAL)**

(Test Conditions (unless otherwise specified):  $T_A = -10$  to  $+70^\circ\text{C}$ ;  $V_D = V_{LS} = V_{LC} = 3.3\text{ V} \pm 5\%$ ,  $V_A = 5\text{ V} \pm 5\%$  or  $3.3\text{ V} \pm 5\%$ ; Full-scale input sine wave: 1 kHz through the active input filter in [Figure 19 on page 48](#) and [Figure 20 on page 48](#); Measurement Bandwidth is 10 Hz to 20 kHz.)

| Parameter                                     |                             | Differential |           |         | Single-Ended |           |         | Unit                  |
|---|-----------------------------|--------------|-----------|---------|--------------|-----------|---------|-----------------------|
|   |                             | Min          | Typ       | Max     | Min          | Typ       | Max     |                       |
| Fs=48 kHz, 96 kHz                             |                             |              |           |         |              |           |         |                       |
| Dynamic Range                                 | A-weighted                  | 99           | 105       | -       | 96           | 102       | -       | dB                    |
|   | unweighted                  | 96           | 102       | -       | 93           | 99        | -       | dB                    |
|   | 40 kHz bandwidth unweighted | -            | 99        | -       | -            | 96        | -       | dB                    |
| Total Harmonic Distortion + Noise<br>(Note 5) | -1 dB                       | -            | -98       | -92     | -            | -95       | -89     | dB                    |
|   | -20 dB                      | -            | -82       | -       | -            | -79       | -       | dB                    |
|   | -60 dB                      | -            | -42       | -       | -            | -39       | -       | dB                    |
|   | 40 kHz bandwidth -1 dB      | -            | -90       | -       | -            | -90       | -       | dB                    |
| ADC1-2 Interchannel Isolation                 |                             | -            | 90        | -       | -            | 90        | -       | dB                    |
| <b>DC Accuracy</b>                            |                             |              |           |         |              |           |         |                       |
| Interchannel Gain Mismatch                    |                             | -            | 0.1       | -       | -            | 0.1       | -       | dB                    |
| Gain Drift                                    |                             | -            | $\pm 100$ | -       | -            | $\pm 100$ | -       | ppm/ $^\circ\text{C}$ |
| <b>Analog Input</b>                           |                             |              |           |         |              |           |         |                       |
| Full-Scale Input Voltage                      |                             | 1.06*VA      | 1.12*VA   | 1.18*VA | 0.53*VA      | 0.56*VA   | 0.59*VA | Vpp                   |
| Differential Input Impedance (Notes 7 & 9)    |                             | 23           | 29        | 32      | -            | -         | -       | k $\Omega$            |
| Single-Ended Input Impedance<br>(Notes 8 & 9) |                             | -            | -         | -       | 23           | 29        | 32      | k $\Omega$            |
| Common Mode Rejection Ratio (CMRR)            |                             | -            | 82        | -       | -            | -         | -       | dB                    |

**ANALOG INPUT CHARACTERISTICS (AUTOMOTIVE)**

(Test Conditions (unless otherwise specified):  $T_A = -40$  to  $+85^\circ\text{C}$ ;  $V_D = V_{LS} = V_{LC} = 3.3\text{ V} \pm 5\%$ ,  $V_A = 5\text{ V} \pm 5\%$  or  $3.3\text{ V} \pm 5\%$ ; Full-scale input sine wave: 1 kHz through the active input filter in [Figure 19 on page 48](#) and [Figure 20 on page 48](#); Measurement Bandwidth is 10 Hz to 20 kHz.)

| Parameter                          |                             | Differential |           |         | Single-Ended |           |          | Unit                  |
|------------------------------------|-----------------------------|--------------|-----------|---------|--------------|-----------|----------|-----------------------|
|                                    |                             | Min          | Typ       | Max     | Min          | Typ       | Max      |                       |
| Fs=48 kHz, 96 kHz                  |                             |              |           |         |              |           |          |                       |
| Dynamic Range                      | A-weighted                  | 97           | 105       | -       | 94           | 102       | -        | dB                    |
|                                    | unweighted                  | 94           | 102       | -       | 91           | 99        | -        | dB                    |
|                                    | 40 kHz bandwidth unweighted | -            | 99        | -       | -            | 96        | -        | dB                    |
| Total Harmonic Distortion + Noise  | (Note 5)                    |              |           |         |              |           | (Note 6) |                       |
|                                    | -1 dB                       | -            | -98       | -90     | -            | -95       | -87/-79  | dB                    |
|                                    | -20 dB                      | -            | -82       | -       | -            | -79       | -        | dB                    |
|                                    | -60 dB                      | -            | -42       | -       | -            | -39       | -        | dB                    |
|                                    | 40 kHz bandwidth -1 dB      | -            | -87       | -       | -            | -87       | -        | dB                    |
| ADC1-2 Interchannel Isolation      |                             | -            | 90        | -       | -            | 90        | -        | dB                    |
| <b>DC Accuracy</b>                 |                             |              |           |         |              |           |          |                       |
| Interchannel Gain Mismatch         |                             | -            | 0.1       | -       | -            | 0.1       | -        | dB                    |
| Gain Drift                         |                             | -            | $\pm 100$ | -       | -            | $\pm 100$ | -        | ppm/ $^\circ\text{C}$ |
| <b>Analog Input</b>                |                             |              |           |         |              |           |          |                       |
| Full-Scale Input Voltage           |                             | 1.04*VA      | 1.12*VA   | 1.20*VA | 0.52*VA      | 0.56*VA   | 0.60*VA  | Vpp                   |
| Differential Input Impedance       | (Notes 7 & 9)               | 23           | 29        | 32      | -            | -         | -        | k $\Omega$            |
| Single-Ended Input Impedance       | (Notes 8 & 9)               | -            | -         | -       | 23           | 29        | 32       | k $\Omega$            |
| Common Mode Rejection Ratio (CMRR) |                             | -            | 82        | -       | -            | -         | -        | dB                    |

**Notes:**

5. Referred to the typical full-scale voltage.
6. Specification for  $V_A = 5\text{ V}$ /specification for  $V_A = 3.3\text{ V}$ .
7. Measured between  $\text{AINx+}$  and  $\text{AINx-}$ .
8. Measured between  $\text{AINxx}$  and  $\text{AGND}$ .
9. The input impedance scales inversely proportionate to the sample rate of the ADC modulator.

**ADC DIGITAL FILTER CHARACTERISTICS**

| Parameter (Notes 10, 11)                |                   | Min    | Typ                 | Max    | Unit |
|---|-------------------|--------|---------------------|--------|------|
| <b>Single-Speed Mode (Note 11)</b>      |                   |        |                     |        |      |
| Passband (Frequency Response)           | to -0.1 dB corner | 0      | -                   | 0.4896 | Fs   |
| Passband Ripple                         |                   | -      | -                   | 0.08   | dB   |
| Stopband                                |                   | 0.5688 | -                   | -      | Fs   |
| Stopband Attenuation                    |                   | 70     | -                   | -      | dB   |
| Total Group Delay                       |                   | -      | 12/Fs               | -      | s    |
| <b>Double-Speed Mode (Note 11)</b>      |                   |        |                     |        |      |
| Passband (Frequency Response)           | to -0.1 dB corner | 0      | -                   | 0.4896 | Fs   |
| Passband Ripple                         |                   | -      | -                   | 0.16   | dB   |
| Stopband                                |                   | 0.5604 | -                   | -      | Fs   |
| Stopband Attenuation                    |                   | 69     | -                   | -      | dB   |
| Total Group Delay                       |                   | -      | 9/Fs                | -      | s    |
| <b>High-Pass Filter Characteristics</b> |                   |        |                     |        |      |
| Frequency Response                      | -3.0 dB           | -      | 1                   | -      | Hz   |
|   | -0.13 dB          | -      | 20                  | -      | Hz   |
| Phase Deviation                         | @ 20 Hz           | -      | 10                  | -      | Deg  |
| Passband Ripple                         |                   | -      | -                   | 0      | dB   |
| Filter Settling Time                    |                   | -      | 10 <sup>5</sup> /Fs | 0      | s    |

**Notes:**

10. Filter response is guaranteed by design.
11. Response is clock-dependent and will scale with Fs. Note that the response plots (Figures 25 to 32) have been normalized to Fs and can be de-normalized by multiplying the X-axis scale by Fs.



**ANALOG OUTPUT CHARACTERISTICS (COMMERCIAL)**

(Test Conditions (unless otherwise specified):  $T_A = -10$  to  $+70^\circ\text{C}$ ;  $V_D = V_{LS} = V_{LC} = 3.3\text{ V}\pm 5\%$ ,  $V_A = 5\text{ V}\pm 5\%$  or  $3.3\text{ V}\pm 5\%$ ; Full-scale 997 Hz output sine wave (see [Note 14](#)) into passive filter in [Figure 25 on page 51](#) and active filter in [Figure 25 on page 51](#); Measurement Bandwidth is 10 Hz to 20 kHz.)

| Parameter   | Differential                |                      |                      | Single-Ended         |                      |                      | Unit                 |                 |
|---|-----------------------------|----------------------|----------------------|----------------------|----------------------|----------------------|----------------------|-----------------|
|   | Min                         | Typ                  | Max                  | Min                  | Typ                  | Max                  |                      |                 |
| <b><i>F<sub>s</sub> = 48 kHz, 96 kHz, 192 kHz</i></b> |                             |                      |                      |                      |                      |                      |                      |                 |
| Dynamic Range   |                             |                      |                      |                      |                      |                      |                      |                 |
| 18 to 24-Bit  | A-weighted                  | 102                  | 108                  | -                    | 99                   | 105                  | -                    | dB              |
|   | unweighted                  | 99                   | 105                  | -                    | 96                   | 102                  | -                    | dB              |
| 16-Bit  | A-weighted                  | -                    | 99                   | -                    | -                    | 96                   | -                    | dB              |
|   | unweighted                  | -                    | 96                   | -                    | -                    | 93                   | -                    | dB              |
| Total Harmonic Distortion + Noise                     |                             |                      |                      |                      |                      |                      |                      |                 |
| 18 to 24-Bit  | 0 dB                        | -                    | -98                  | -92                  | -                    | -95                  | -89                  | dB              |
|   | -20 dB                      | -                    | -85                  | -                    | -                    | -82                  | -                    | dB              |
|   | -60 dB                      | -                    | -45                  | -                    | -                    | -42                  | -                    | dB              |
| 16-Bit  | 0 dB                        | -                    | -93                  | -                    | -                    | -90                  | -                    | dB              |
|   | -20 dB                      | -                    | -76                  | -                    | -                    | -73                  | -                    | dB              |
|   | -60 dB                      | -                    | -36                  | -                    | -                    | -33                  | -                    | dB              |
| Interchannel Isolation                                | (1 kHz)                     | -                    | 100                  | -                    | -                    | 100                  | -                    | dB              |
| <b><i>Analog Output</i></b>                           |                             |                      |                      |                      |                      |                      |                      |                 |
| Full-Scale Output                                     |                             | 1.235•V <sub>A</sub> | 1.300•V <sub>A</sub> | 1.365•V <sub>A</sub> | 0.618•V <sub>A</sub> | 0.650•V <sub>A</sub> | 0.683•V <sub>A</sub> | V <sub>pp</sub> |
| Interchannel Gain Mismatch                            |                             | -                    | 0.1                  | 0.25                 | -                    | 0.1                  | 0.25                 | dB              |
| Gain Drift  |                             | -                    | ±100                 | -                    | -                    | ±100                 | -                    | ppm/°C          |
| Output Impedance                                      |                             | -                    | 100                  | -                    | -                    | 100                  | -                    | Ω               |
| DC Current draw from an AOUT pin                      | ( <a href="#">Note 13</a> ) | -                    | -                    | 10                   | -                    | -                    | 10                   | μA              |
| AC-Load Resistance (R <sub>L</sub> )                  | ( <a href="#">Note 15</a> ) | 3                    | -                    | -                    | 3                    | -                    | -                    | kΩ              |
| Load Capacitance (C <sub>L</sub> )                    | ( <a href="#">Note 15</a> ) | -                    | -                    | 100                  | -                    | -                    | 100                  | pF              |

## ANALOG OUTPUT CHARACTERISTICS (AUTOMOTIVE)

(Test Conditions (unless otherwise specified):  $T_A = -40$  to  $+85^\circ\text{C}$ ;  $V_D = V_{LS} = V_{LC} = 3.3\text{ V} \pm 5\%$ ,  $V_A = 5\text{ V} \pm 5\%$  or  $3.3\text{ V} \pm 5\%$ ; Full-scale 997 Hz output sine wave (see [Note 14](#)) in [Figure 25 on page 51](#) and [Figure 25 on page 51](#); Measurement Bandwidth is 10 Hz to 20 kHz.)

| Parameter   | Differential         |                      |                      | Single-Ended         |                      |                      | Unit |                 |
|---|----------------------|----------------------|----------------------|----------------------|----------------------|----------------------|------|-----------------|
|   | Min                  | Typ                  | Max                  | Min                  | Typ                  | Max                  |      |                 |
| <b><i>F<sub>s</sub> = 48 kHz, 96 kHz, 192 kHz</i></b> |                      |                      |                      |                      |                      |                      |      |                 |
| Dynamic Range   | (Note 12)            |                      |                      | (Note 12)            |                      |                      |      |                 |
| 18 to 24-Bit  | A-weighted           | 100/97               | 108                  | -                    | 97/94                | 105                  | -    | dB              |
|   | unweighted           | 97/94                | 105                  | -                    | 94/91                | 102                  | -    | dB              |
| 16-Bit  | A-weighted           | -                    | 99                   | -                    | -                    | 96                   | -    | dB              |
|   | unweighted           | -                    | 96                   | -                    | -                    | 93                   | -    | dB              |
| Total Harmonic Distortion + Noise                     |                      |                      |                      |                      |                      |                      |      |                 |
| 18 to 24-Bit  | 0 dB                 | -                    | -98                  | -90                  | -                    | -95                  | -87  | dB              |
|   | -20 dB               | -                    | -85                  | -                    | -                    | -82                  | -    | dB              |
|   | -60 dB               | -                    | -45                  | -                    | -                    | -42                  | -    | dB              |
| 16-Bit  | 0 dB                 | -                    | -93                  | -                    | -                    | -90                  | -    | dB              |
|   | -20 dB               | -                    | -76                  | -                    | -                    | -73                  | -    | dB              |
|   | -60 dB               | -                    | -36                  | -                    | -                    | -33                  | -    | dB              |
| Interchannel Isolation (1 kHz)                        | -                    | 100                  | -                    | -                    | 100                  | -                    | -    | dB              |
| <b><i>Analog Output</i></b>                           |                      |                      |                      |                      |                      |                      |      |                 |
| Full-Scale Output                                     | 1.210•V <sub>A</sub> | 1.300•V <sub>A</sub> | 1.392•V <sub>A</sub> | 0.605•V <sub>A</sub> | 0.650•V <sub>A</sub> | 0.696•V <sub>A</sub> |      | V <sub>pp</sub> |
| Interchannel Gain Mismatch                            | -                    | 0.1                  | 0.25                 | -                    | 0.1                  | 0.25                 |      | dB              |
| Gain Drift  | -                    | ±100                 | -                    | -                    | ±100                 | -                    |      | ppm/°C          |
| Output Impedance                                      | -                    | 100                  | -                    | -                    | 100                  | -                    |      | Ω               |
| DC Current draw from an AOUT pin (Note 13)            | -                    | -                    | 10                   | -                    | -                    | 10                   |      | μA              |
| AC-Load Resistance (R <sub>L</sub> ) (Note 15)        | 3                    | -                    | -                    | 3                    | -                    | -                    |      | kΩ              |
| Load Capacitance (C <sub>L</sub> ) (Note 15)          | -                    | -                    | 100                  | -                    | -                    | 100                  |      | pF              |

### Notes:

12. Specification for  $V_A = 5\text{ V}$ /specification for  $V_A = 3.3\text{ V}$ .
13. Guaranteed by design. The DC current draw represents the allowed current draw from the AOUT pin due to typical leakage through the electrolytic DC-blocking capacitors.
14. One LSB of triangular PDF dither is added to data.
15. Guaranteed by design. See [3](#).  $R_L$  and  $C_L$  reflect the recommended minimum resistance and maximum capacitance required for the internal op-amp's stability and signal integrity. In this circuit topology,  $C_L$  will effectively move the dominant pole of the two-pole amp in the output stage. Increasing this value beyond the recommended 100 pF can cause the internal op-amp to become unstable. See [“External Filters” on page 48](#) for a recommended output filter.

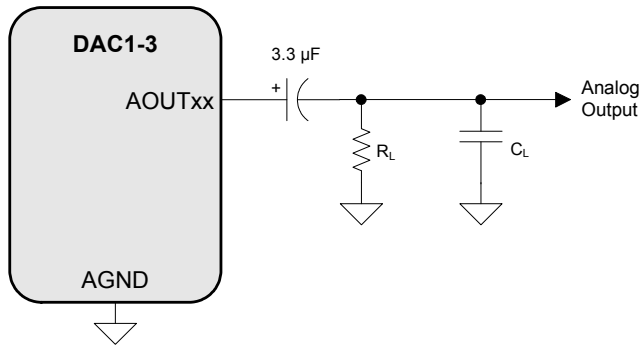


Figure 3. Output Test Load

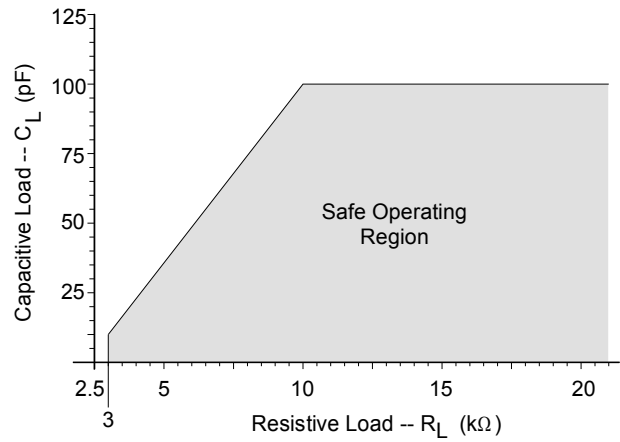


Figure 4. Maximum Loading

**COMBINED DAC INTERPOLATION & ON-CHIP ANALOG FILTER RESPONSE**

| Parameter (Notes 10, 16)           | Min                | Typ    | Max   | Unit        |    |
|------------------------------------|--------------------|--------|-------|-------------|----|
| <b>Single-Speed Mode</b>           |                    |        |       |             |    |
| Passband (Frequency Response)      | to -0.05 dB corner | 0      | -     | 0.4780      | Fs |
|                                    | to -3 dB corner    | 0      | -     | 0.4996      | Fs |
| Frequency Response 10 Hz to 20 kHz | -0.2               | -      | +0.08 | dB          |    |
| StopBand                           | 0.5465             | -      | -     | Fs          |    |
| StopBand Attenuation (Note 17)     | 50                 | -      | -     | dB          |    |
| Group Delay                        | -                  | 10/Fs  | -     | s           |    |
| De-emphasis Error (Note 18)        | Fs = 32 kHz        | -      | -     | +1.5/+0     | dB |
|                                    | Fs = 44.1 kHz      | -      | -     | +0.05/-0.25 | dB |
|                                    | Fs = 48 kHz        | -      | -     | -0.2/-0.4   | dB |
| <b>Double-Speed Mode</b>           |                    |        |       |             |    |
| Passband (Frequency Response)      | to -0.1 dB corner  | 0      | -     | 0.4650      | Fs |
|                                    | to -3 dB corner    | 0      | -     | 0.4982      | Fs |
| Frequency Response 10 Hz to 20 kHz | -0.2               | -      | +0.7  | dB          |    |
| StopBand                           | 0.5770             | -      | -     | Fs          |    |
| StopBand Attenuation (Note 17)     | 55                 | -      | -     | dB          |    |
| Group Delay                        | -                  | 5/Fs   | -     | s           |    |
| <b>Quad-Speed Mode</b>             |                    |        |       |             |    |
| Passband (Frequency Response)      | to -0.1 dB corner  | 0      | -     | 0.397       | Fs |
|                                    | to -3 dB corner    | 0      | -     | 0.476       | Fs |
| Frequency Response 10 Hz to 20 kHz | -0.2               | -      | +0.05 | dB          |    |
| StopBand                           | 0.7                | -      | -     | Fs          |    |
| StopBand Attenuation (Note 17)     | 51                 | -      | -     | dB          |    |
| Group Delay                        | -                  | 2.5/Fs | -     | s           |    |

**Notes:**

16. Response is clock-dependent and will scale with Fs. Note that the response plots (Figures 33 to 44) have been normalized to Fs and can be de-normalized by multiplying the X-axis scale by Fs.
17. Single- and Double-Speed Mode Measurement Bandwidth is from Stopband to 3 Fs.  
Quad-Speed Mode Measurement Bandwidth is from Stopband to 1.34 Fs.
18. De-emphasis is only available in Single-Speed Mode.

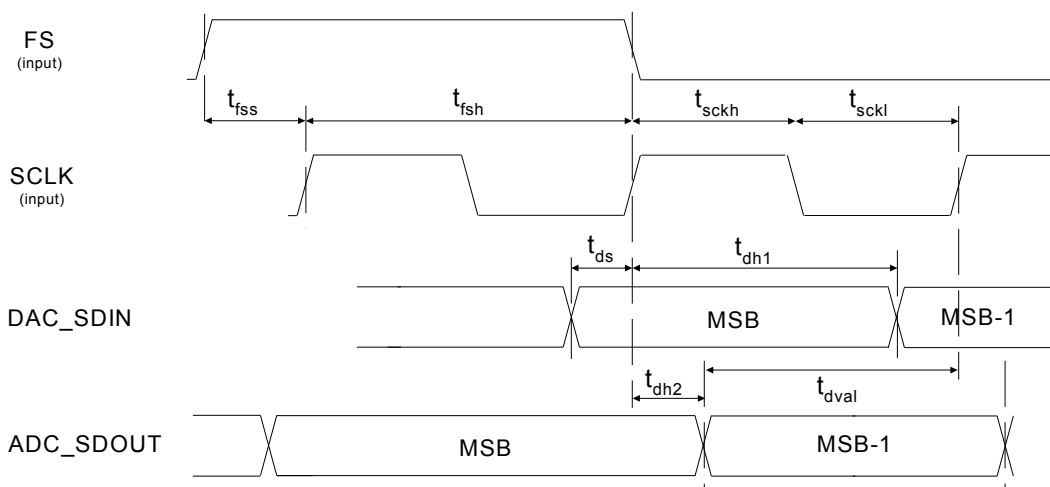
## SWITCHING SPECIFICATIONS - ADC/DAC PORT

(Inputs: Logic 0 = DGND, Logic 1 = VLS, ADC\_SDOOUT C<sub>LOAD</sub> = 15 pF.)

| Parameters                                  | Symbol                      | Min            | Max | Units |     |
|---|-----------------------------|----------------|-----|-------|-----|
| <b>Slave Mode</b>                           |                             |                |     |       |     |
| RST pin Low Pulse Width (Note 19)           |                             | 1              | -   | ms    |     |
| MCLK Frequency                              |                             | 0.512          | 50  | MHz   |     |
| MCLK Duty Cycle (Note 20)                   |                             | 45             | 55  | %     |     |
| Input Sample Rate (FS pin)                  | Single-Speed Mode           | F <sub>s</sub> | 4   | 50    | kHz |
|   | Double-Speed Mode (Note 21) | F <sub>s</sub> | 50  | 100   |     |
|   | Quad-Speed Mode (Note 22)   | F <sub>s</sub> | 100 | 200   |     |
| SCLK Duty Cycle                             |                             | 45             | 55  | %     |     |
| SCLK High Time                              | t <sub>sckh</sub>           | 8              | -   | ns    |     |
| SCLK Low Time                               | t <sub>sckl</sub>           | 8              | -   | ns    |     |
| FS Rising Edge to SCLK Rising Edge          | t <sub>fss</sub>            | 5              | -   | ns    |     |
| SCLK Rising Edge to FS Falling Edge         | t <sub>fsh</sub>            | 16             | -   | ns    |     |
| DAC_SDIN Setup Time Before SCLK Rising Edge | t <sub>ds</sub>             | 3              | -   | ns    |     |
| DAC_SDIN Hold Time After SCLK Rising Edge   | t <sub>dh</sub>             | 5              | -   | ns    |     |
| DAC_SDIN Hold Time After SCLK Rising Edge   | t <sub>dh1</sub>            | 5              | -   | ns    |     |
| ADC_SDOOUT Hold Time After SCLK Rising Edge | t <sub>dh2</sub>            | 10             | -   | ns    |     |
| ADC_SDOOUT Valid Before SCLK Rising Edge    | t <sub>dval</sub>           | 15             | -   | ns    |     |

### Notes:

19. After powering up the CS42432,  $\overline{\text{RST}}$  should be held low after the power supplies and clocks are settled.
20. See [Table 5 on page 41](#) for suggested MCLK frequencies.
21. VLS is limited to nominal 2.5 V to 5.0 V operation only.
22. ADC does not meet timing specification for Quad-Speed Mode.

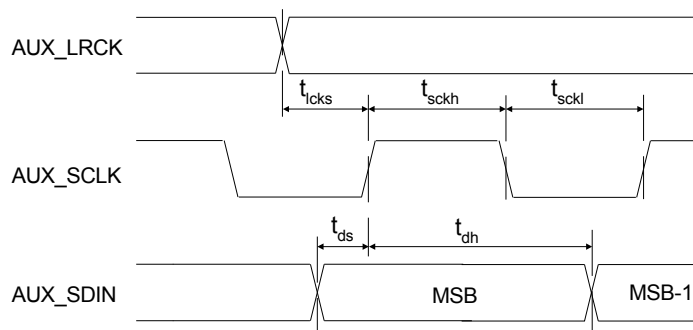


**Figure 5. TDM Serial Audio Interface Timing**

## SWITCHING CHARACTERISTICS - AUX PORT

(Inputs: Logic 0 = DGND, Logic 1 = VLS.)

| Parameters                                    | Symbol     | Min | Max                    | Units |
|---|------------|-----|------------------------|-------|
| <b>Master Mode</b>                            |            |     |                        |       |
| Output Sample Rate (AUX_LRCK) All Speed Modes | $F_s$      | -   | LRCK                   | kHz   |
| AUX_SCLK Frequency                            |            | -   | $64 \cdot \text{LRCK}$ | kHz   |
| AUX_SCLK Duty Cycle                           |            | 45  | 55                     | %     |
| AUX_LRCK Edge to SCLK Rising Edge             | $t_{lcks}$ | -   | 5                      | ns    |
| AUX_SDIN Setup Time Before SCLK Rising Edge   | $t_{ds}$   | 3   | -                      | ns    |
| AUX_SDIN Hold Time After SCLK Rising Edge     | $t_{dh}$   | 5   | -                      | ns    |



**Figure 6. Serial Audio Interface Slave Mode Timing**

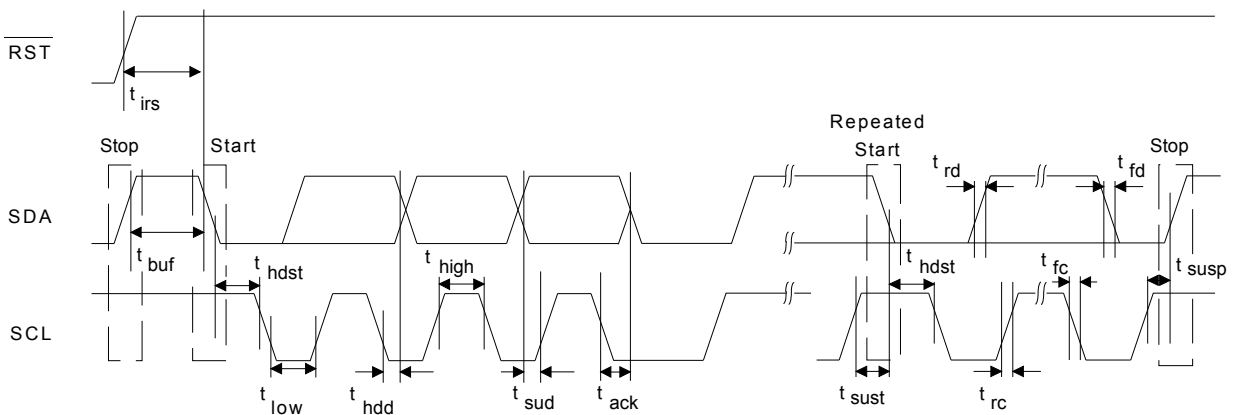
**SWITCHING SPECIFICATIONS - CONTROL PORT - I<sup>2</sup>C MODE**

(VLC = 1.8 V - 5.0 V, VLS = VD = 3.3 V, VA = 5.0 V; Inputs: Logic 0 = DGND, Logic 1 = VLC, SDA C<sub>L</sub> = 30 pF)

| Parameter  | Symbol     | Min | Max  | Unit    |
|--|------------|-----|------|---------|
| SCL Clock Frequency                                    | $f_{scl}$  | -   | 100  | kHz     |
| RST Rising Edge to Start                               | $t_{irs}$  | 500 | -    | ns      |
| Bus Free Time Between Transmissions                    | $t_{buf}$  | 4.7 | -    | $\mu$ s |
| Start Condition Hold Time (prior to first clock pulse) | $t_{hdst}$ | 4.0 | -    | $\mu$ s |
| Clock Low time   | $t_{low}$  | 4.7 | -    | $\mu$ s |
| Clock High Time  | $t_{high}$ | 4.0 | -    | $\mu$ s |
| Setup Time for Repeated Start Condition                | $t_{sust}$ | 4.7 | -    | $\mu$ s |
| SDA Hold Time from SCL Falling (Note 23)               | $t_{hdd}$  | 0   | -    | $\mu$ s |
| SDA Setup time to SCL Rising                           | $t_{sud}$  | 250 | -    | ns      |
| Rise Time of SCL and SDA (Note 24)                     | $t_{rc}$   | -   | 1    | $\mu$ s |
| Fall Time SCL and SDA (Note 24)                        | $t_{fc}$   | -   | 300  | ns      |
| Setup Time for Stop Condition                          | $t_{susp}$ | 4.7 | -    | $\mu$ s |
| Acknowledge Delay from SCL Falling                     | $t_{ack}$  | 300 | 1000 | ns      |

**Notes:**

23. Data must be held for sufficient time to bridge the transition time,  $t_{fc}$ , of SCL.
24. Guaranteed by design.


**Figure 7. Control Port Timing - I<sup>2</sup>C Format**

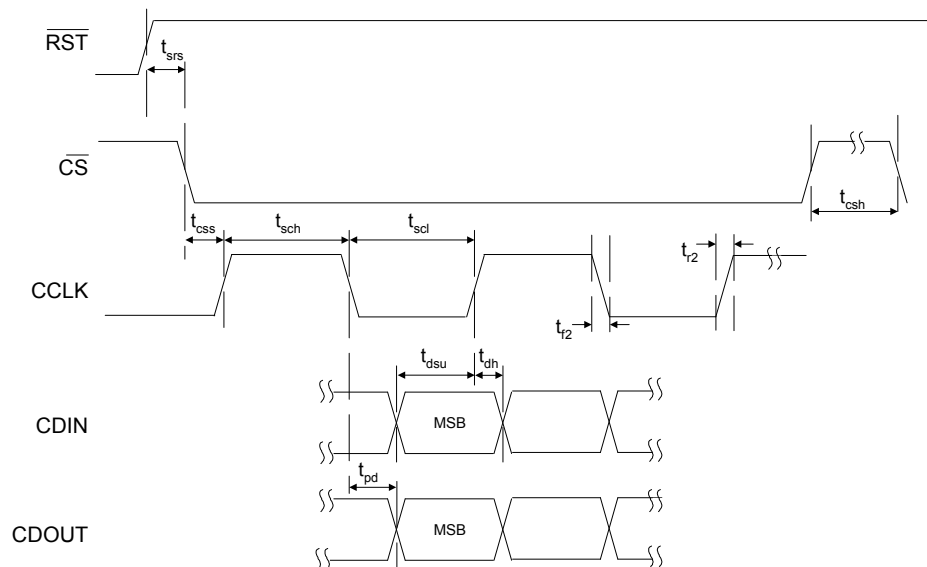
**SWITCHING SPECIFICATIONS - CONTROL PORT - SPI FORMAT**

(VLC = 1.8 V - 5.0 V, VLS = VD = 3.3 V, VA = 5.0 V; Inputs: Logic 0 = DGND, Logic 1 = VLC, CDOUT C<sub>L</sub> = 30 pF)

| Parameter                                       | Symbol             | Min | Max | Units   |
|---|--------------------|-----|-----|---------|
| CCLK Clock Frequency                            | $f_{sck}$          | 0   | 6.0 | MHz     |
| RST Rising Edge to $\overline{CS}$ Falling      | $t_{srs}$          | 20  | -   | ns      |
| $\overline{CS}$ Falling to CCLK Edge            | $t_{css}$          | 20  | -   | ns      |
| $\overline{CS}$ High Time Between Transmissions | $t_{csh}$          | 1.0 | -   | $\mu$ s |
| CCLK Low Time                                   | $t_{scl}$          | 66  | -   | ns      |
| CCLK High Time                                  | $t_{sch}$          | 66  | -   | ns      |
| CDIN to CCLK Rising Setup Time                  | $t_{dsu}$          | 40  | -   | ns      |
| CCLK Rising to DATA Hold Time                   | (Note 25) $t_{dh}$ | 15  | -   | ns      |
| CCLK Falling to CDOUT Stable                    | $t_{pd}$           | -   | 50  | ns      |
| Rise Time of CDOUT                              | $t_{r1}$           | -   | 25  | ns      |
| Fall Time of CDOUT                              | $t_{f1}$           | -   | 25  | ns      |
| Rise Time of CCLK and CDIN                      | (Note 26) $t_{r2}$ | -   | 100 | ns      |
| Fall Time of CCLK and CDIN                      | (Note 26) $t_{f2}$ | -   | 100 | ns      |

**Notes:**

25. Data must be held for sufficient time to bridge the transition time of CCLK.

26. For  $f_{sck} < 1$  MHz.

**Figure 8. Control Port Timing - SPI Format**



## DC ELECTRICAL CHARACTERISTICS

(AGND = 0 V; all voltages with respect to ground.)

| Parameters                                | Symbol                              | Min | Typ    | Max | Units |
|---|-------------------------------------|-----|--------|-----|-------|
| <b>Normal Operation (Note 27)</b>         |                                     |     |        |     |       |
| Power Supply Current                      | VA = 5.0 V                          | -   | 80     | -   | mA    |
|   | VLS = VLC = VD = 3.3 V<br>(Note 28) | -   | 60.6   | -   | mA    |
| Power Dissipation                         | VLS = VLC = VD = 3.3 V, 5 V         | -   | 600    | 850 | mW    |
| Power Supply Rejection Ratio<br>(Note 29) | 1 kHz                               | -   | 60     | -   | dB    |
|   | 60 Hz                               | -   | 40     | -   | dB    |
| <b>Power-Down Mode (Note 30)</b>          |                                     |     |        |     |       |
| Power Dissipation                         | VLS = VLC = VD = 3.3 V, VA = 5 V    | -   | 1.25   | -   | mW    |
| <b>VQ Characteristics</b>                 |                                     |     |        |     |       |
| Nominal Voltage                           |                                     | -   | 0.5•VA | -   | V     |
| Output Impedance                          |                                     | -   | 23     | -   | kΩ    |
| DC Current Source/Sink (Note 31)          |                                     | -   | -      | 10  | μA    |
| FILT+ Nominal Voltage                     |                                     | -   | VA     | -   | V     |

### Notes:

27. Normal operation is defined as  $\overline{RST} = HI$  with a 997 Hz, 0 dBFS input to the DAC and AUX port, and a 1 kHz, -1 dB analog input to the ADC port sampled at the highest  $F_s$  for each speed mode. DAC outputs are open, unless otherwise specified.
28.  $I_{DT}$  measured with no external loading on pin (SDA).
29. Valid with the recommended capacitor values on FILT+ and VQ. Increasing the capacitance will also increase the PSRR.
30. Power-Down Mode is defined as  $\overline{RST} = LO$  with all clocks and data lines held static and no analog input.
31. Guaranteed by design. The DC current draw represents the allowed current draw from the VQ pin due to typical leakage through the electrolytic de-coupling capacitors.

## DIGITAL INTERFACE SPECIFICATIONS & CHARACTERISTICS

| Parameters (Note 32)                    | Symbol       | Min     | Typ | Max     | Units |
|---|--------------|---------|-----|---------|-------|
| High-Level Output Voltage at $I_o=2$ mA | Serial Port  | VLS-1.0 | -   | -       | V     |
|   | Control Port | VLC-1.0 | -   | -       | V     |
| Low-Level Output Voltage at $I_o=2$ mA  | Serial Port  | -       | -   | 0.4     | V     |
|   | Control Port | -       | -   | 0.4     | V     |
| High-Level Input Voltage                | Serial Port  | 0.7xVLS | -   | -       | V     |
|   | Control Port | 0.7xVLC | -   | -       | V     |
| Low-Level Input Voltage                 | Serial Port  | -       | -   | 0.2xVLS | V     |
|   | Control Port | -       | -   | 0.2xVLC | V     |
| Leakage Current                         | $I_{in}$     | -       | -   | ±10     | μA    |
| Input Capacitance (Note 24)             |              | -       | -   | 10      | pF    |

### Notes:

32. See “Digital I/O Pin Characteristics” on page 8 for serial and control port power rails.

## 5. APPLICATIONS

### 5.1 Overview

The CS42432 is a highly integrated mixed signal 24-bit audio CODEC comprised of 4 analog-to-digital converters (ADC) implemented using multi-bit delta-sigma techniques and 6 digital-to-analog converters (DAC) also implemented using multi-bit delta-sigma techniques.

Other functions integrated within the CODEC include independent digital volume controls for each DAC, digital de-emphasis filters for the DAC, digital volume control with gain on each ADC channel, ADC high-pass filters, and an on-chip voltage reference.

The serial audio interface ports allow up to 6 DAC channels and 6 ADC channels in a Time-Division Multiplexed (TDM) interface format. The CS42432 features an Auxiliary Port used to accommodate an additional two channels of PCM data on the ADC\_SDOOUT data line in the TDM digital interface format. See [“AUX Port Digital Interface Formats” on page 32](#) for details.

The CS42432 operates in one of three oversampling modes based on the input sample rate. Mode selection is determined automatically based on the MCLK frequency setting. Single-Speed Mode (SSM) supports input sample rates up to 50 kHz and uses a 128x oversampling ratio. Double-Speed Mode (DSM) supports input sample rates up to 100 kHz and uses an oversampling ratio of 64x. Quad-Speed Mode (QSM) supports input sample rates up to 200 kHz and uses an oversampling ratio of 32x (**Note:** QSM for the ADC is only supported in the I<sup>2</sup>S, Left-Justified, Right-Justified interface formats. QSM is not supported for the DAC). **Note:** QSM is only available in Software Mode (see [“System Clocking” on page 31](#) for details).

All functions can be configured through software via a serial control port operable in SPI Mode or in I<sup>2</sup>C Mode. A Hardware, Stand-Alone Mode is also available, allowing configuration of the CODEC on a more limited basis. See Table 2 for the default configuration in Hardware Mode.

[Figure 1 on page 11](#) and [Figure 2 on page 12](#) show the recommended connections for the CS42432 in Software and Hardware Mode, respectively. See [“Register Description” on page 39](#) for the default register settings and options in Software Mode.

| Hardware Mode Feature Summary     |   |                  |                                 |
|-----------------------------------|---|------------------|---------------------------------|
| Function                          | Default Configuration                         | Hardware Control | Note                            |
| Power Down ADC                    | All ADC's are enabled                         | -                | -                               |
| Power Down DAC                    | All DAC's are enabled                         | -                | -                               |
| Power Down Device                 | Device is powered up                          | -                | -                               |
| MCLK Frequency Select             | Selectable between 256Fs and 512Fs            | “MFREQ” pin 3    | see <a href="#">Section 5.4</a> |
| Freeze Control                    | N/A   | -                | -                               |
| AUX Serial Port Interface Format  | Left-Justified                                | -                | -                               |
| ADC1/ADC2 High Pass Filter Freeze | High Pass Filter is always enabled            | -                | -                               |
| DAC De-Emphasis                   | No De-Emphasis applied                        | -                | -                               |
| ADC1/ADC2 Single-Ended Mode       | Disabled                                      | -                | -                               |
| DAC Volume Control/Mute/Invert    | All DAC Volume = 0 dB, un-muted, not inverted | -                | -                               |
| ADC Volume Control                | All ADC Volume = 0 dB                         | -                | -                               |
| DAC Soft Ramp/Zero Cross          | Immediate Change                              | -                | -                               |
| ADC Soft Ramp/Zero Cross          | Immediate Change                              | -                | -                               |
| DAC Auto-Mute                     | Enabled                                       | -                | -                               |

**Table 2. Hardware Configurable Settings**

| Hardware Mode Feature Summary |                       |                  |      |
|-------------------------------|-----------------------|------------------|------|
| Function                      | Default Configuration | Hardware Control | Note |
| Status Interrupt              | N/A                   | -                | -    |

**Table 2. Hardware Configurable Settings (Continued)**

## 5.2 Analog Inputs

### 5.2.1 Line-Level Inputs

AINx+ and AINx- are the line-level differential analog inputs internally biased to VQ, approximately VA/2. [Figure 9 on page 27](#) shows the full-scale analog input levels. The CS42432 also accommodates single-ended signals on all inputs, AIN1-AIN4. See [“ADC Input Filter” on page 48](#) for the recommended input filters.

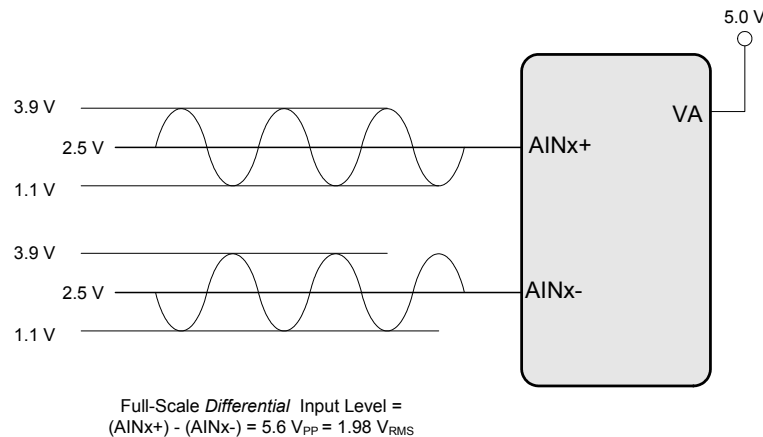
#### 5.2.1.1 Hardware Mode

AIN Volume Control and ADC Overflow status are not accessible in Hardware Mode.

#### 5.2.1.2 Software Mode

For single-ended operation on ADC1-ADC2 (AIN1 to AIN4), the ADCx\_SINGLE bit in the register [“ADC Control & DAC De-Emphasis \(Address 05h\)” on page 42](#) must be set appropriately (see [Figure 20 on page 48](#) for required external components).

The gain/attenuation of the signal can be adjusted for each AINx independently through the [“AINX Volume Control \(Address 11h-14h\)” on page 45](#). The ADC output data is in 2’s complement binary format. For inputs above positive full scale or below negative full scale, the ADC will output 7FFFFFFH or 800000H, respectively, and cause the ADC Overflow bit in the register [“Status \(Address 19h\) \(Read Only\)” on page 46](#) to be set to a ‘1’.


**Figure 9. Full-Scale Input**

### 5.2.2 High-Pass Filter and DC Offset Calibration

The high-pass filter continuously subtracts a measure of the DC offset from the output of the decimation filter. If the high-pass filter is disabled during normal operation, the current value of the DC offset for the corresponding channel is frozen and this DC offset will continue to be subtracted from the conversion result. This feature makes it possible to perform a system DC offset calibration by:

1. Running the CS42432 with the high-pass filter enabled until the filter settles. See the Digital Filter Characteristics for filter settling time.
2. Disabling the high-pass filter and freezing the stored DC offset.

### 5.2.2.1 Hardware Mode

The high pass filters for ADC1 and ADC2 are permanently enabled in Hardware Mode.

### 5.2.2.2 Software Mode

The high-pass filter for ADC1/ADC2 can be enabled and disabled. The high-pass filters are controlled using the HPF\_FREEZE bit in the register “ADC Control & DAC De-Emphasis (Address 05h)” on page 42.

## 5.3 Analog Outputs

### 5.3.1 Initialization

The initialization and Power-Down sequence flow chart is shown in [Figure 10 on page 29](#). The CS42432 enters a power-down state upon initial power-up. The interpolation and decimation filters, delta-sigma modulators and control port registers are reset. The internal voltage reference, multi-bit digital-to-analog and analog-to-digital converters and switched-capacitor low-pass filters are powered down.

The device remains in the power-down state until the RST pin is brought high. The control port is accessible once RST is high, and the desired register settings can be loaded per the interface descriptions in the “[Control Port Description and Timing](#)” on page 33. In Hardware Mode operation, the Hardware Mode pins must be set up before RST is brought high. All features will default to the Hardware Mode defaults as listed in [Table 2](#).

VQ will quickly charge to  $V_A/2$  upon initial power up. Once MCLK is valid and the PDN bit is set to ‘0’, the internal voltage reference, FILT+, will ramp up to approximately  $V_A$ . Power is applied to the D/A converters and switched-capacitor filters, and the analog outputs are clamped to the quiescent voltage, VQ. Once LRCK is valid, MCLK occurrences are counted over one LRCK period to determine the MCLK/LRCK frequency ratio. After an approximate 2000 sample period delay, normal operation begins.

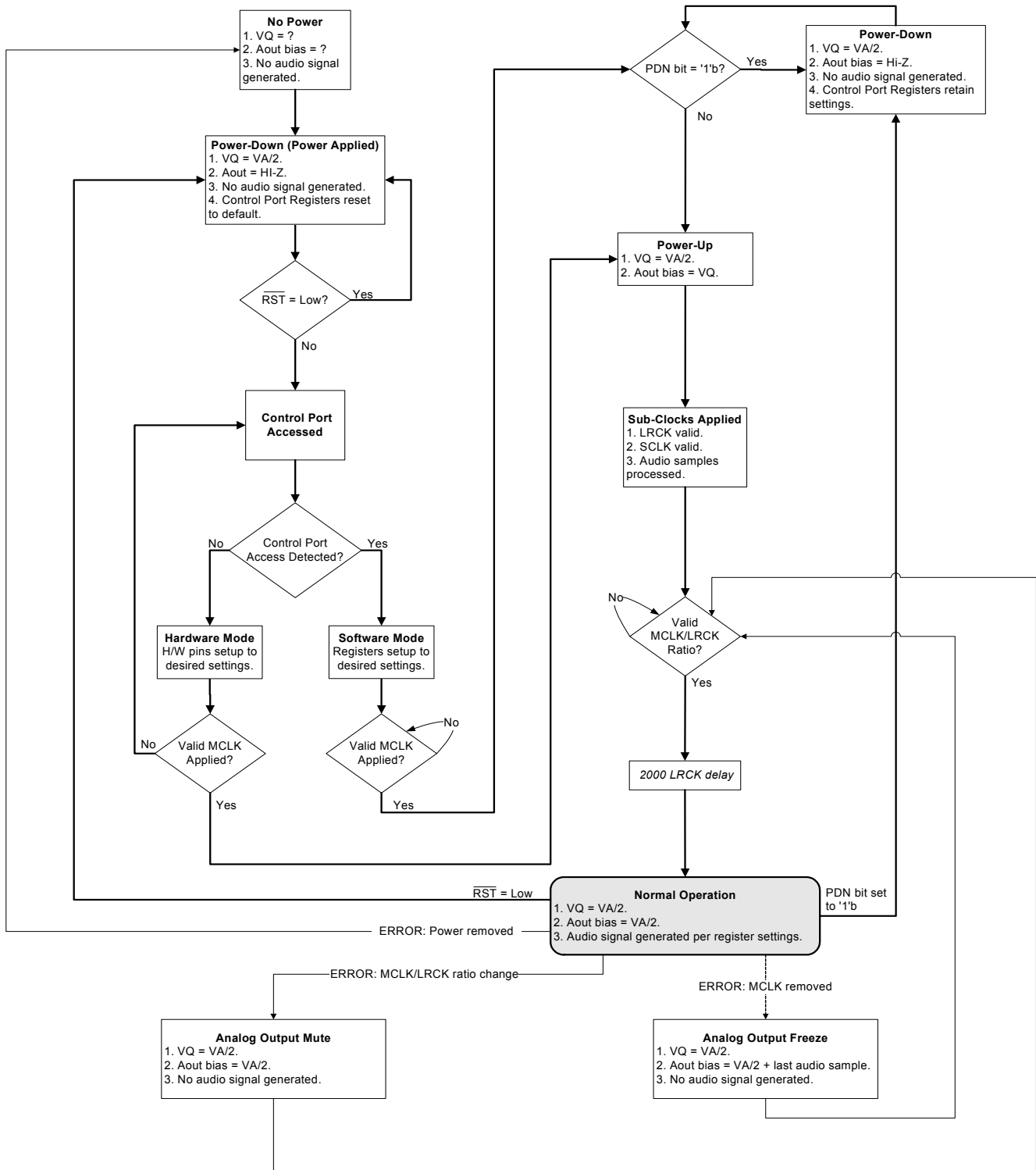
### 5.3.2 Line-Level Outputs and Filtering

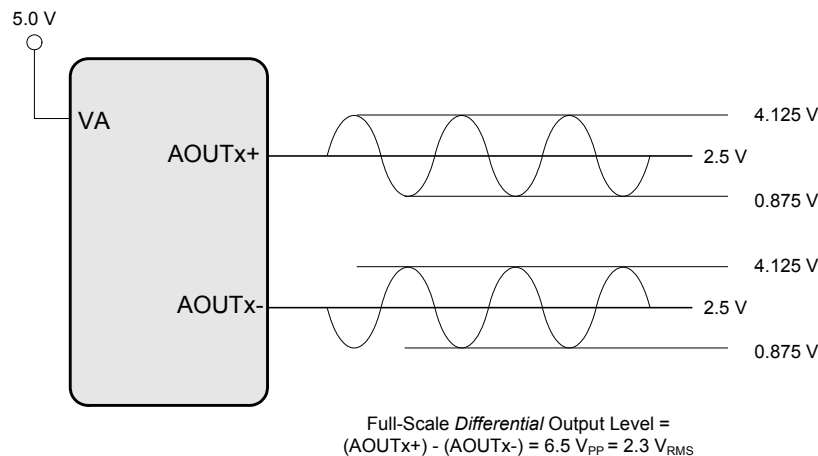
The CS42432 contains on-chip buffer amplifiers capable of producing line-level differential as well as single-ended outputs on AOUT1-AOUT6. These amplifiers are biased to a quiescent DC level of approximately VQ.

The delta-sigma conversion process produces high-frequency noise beyond the audio passband, most of which is removed by the on-chip analog filters. The remaining out-of-band noise can be attenuated using an off-chip low-pass filter.

See “[DAC Output Filter](#)” on page 50 for recommended output filter. The active filter configuration accounts for the normally differing AC loads on the AOUTx+ and AOUTx- differential output pins. Also shown is a passive filter configuration which minimizes costs and the number of components.

[Figure 11](#) shows the full-scale analog output levels. All outputs are internally biased to VQ, approximately  $V_A/2$ .


**Figure 10. Audio Output Initialization Flow Chart**



**Figure 11. Full-Scale Output**

### 5.3.3 Digital Volume Control

#### 5.3.3.1 Hardware Mode

DAC Volume Control and Mute are not accessible in Hardware Mode.

#### 5.3.3.2 Software Mode

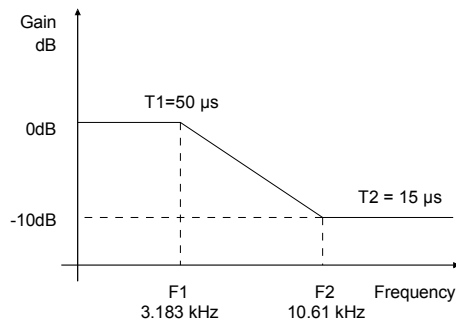
Each DAC's output level is controlled via the Volume Control registers operating over the range of 0 to -127.5 dB attenuation with 0.5 dB resolution. See [“AOUTX Volume Control \(Addresses 08h-0D\)” on page 45](#). Volume control changes are programmable to ramp in increments of 0.125 dB at the rate controlled by the SZC[1:0] bits in the Digital Volume Control register. See [“Transition Control \(Address 06h\)” on page 43](#).

Each output can be independently muted via mute control bits in the register [“DAC Channel Mute \(Address 07h\)” on page 44](#). When enabled, each AOUTx\_MUTE bit attenuates the corresponding DAC to its maximum value (-127.5 dB). When the AOUTx\_MUTE bit is disabled, the corresponding DAC returns to the attenuation level set in the Volume Control register. The attenuation is ramped up and down at the rate specified by the SZC[1:0] bits.

### 5.3.4 De-Emphasis Filter

The CS42432 includes on-chip digital de-emphasis optimized for a sample rate of 44.1 kHz. The filter response is shown in [Figure 12](#). The de-emphasis feature is included to accommodate audio recordings that utilize 50/15  $\mu$ s pre-emphasis equalization as a means of noise reduction.

De-emphasis is only available in Single-Speed Mode. Please see [“DAC De-Emphasis Control \(DAC\\_DEM\)” on page 42](#) for de-emphasis control.



**Figure 12. De-Emphasis Curve**

## 5.4 System Clocking

The CODEC serial audio interface ports operate as a slave and accept externally generated clocks.

The CODEC requires external generation of the master clock (MCLK). The frequency of this clock must be an integer multiple of, and synchronous with, the system sample rate,  $F_s$ .

### 5.4.1 Hardware Mode

The allowable ratios include 256Fs and 512Fs in Single-Speed Mode and 256Fs in Double-Speed Mode. The frequency of MCLK must be specified using the MFREQ (pin 3). See [Table 3](#) for the required frequency range.

| MFREQ | Description               | Ratio (xFs) |     |     |
|-------|---------------------------|-------------|-----|-----|
|       |                           | SSM         | DSM | QSM |
| 0     | 1.5360 MHz to 12.8000 MHz | 256         | N/A | N/A |
| 1     | 2.0480 MHz to 25.6000 MHz | 512         | 256 | N/A |

**Table 3. MCLK Frequency Settings**

### 5.4.2 Software Mode

The frequency range of MCLK must be specified using the MFREQ bits in register “MCLK Frequency (MFREQ[2:0])” on [page 41](#).

## 5.5 CODEC Digital Interface

The ADC and DAC serial ports operate as a slave and support the TDM digital interface formats with varying bit depths from 16 to 32 as shown in [Figure 13](#), [Figure 14](#), and [Figure 15](#). Data is clocked out of the ADC on the falling edge of SCLK and clocked into the DAC on the rising edge.

TDM is the only interface supported in Hardware and Software Mode.

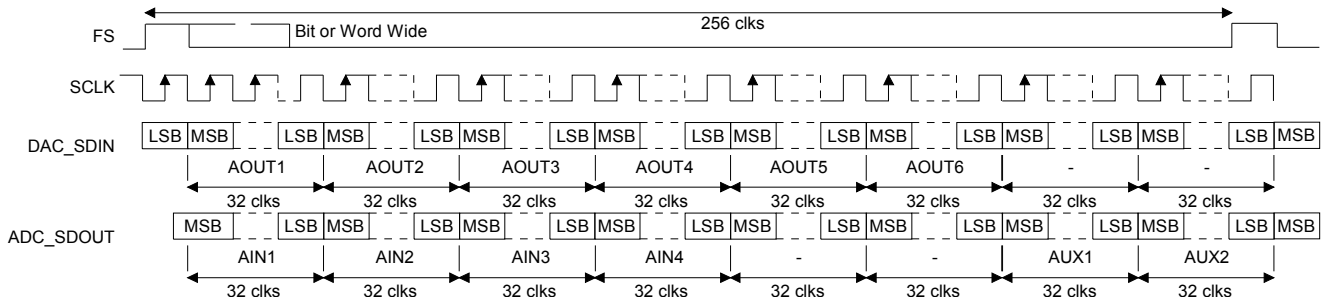
### 5.5.1 TDM

TDM data is received most significant bit (MSB) first, on the second rising edge of the SCLK occurring after a an FS rising edge. All data is valid on the rising edge of SCLK. The AIN1 MSB is transmitted early, but is guaranteed valid for a specified time after SCLK rises. All other bits are transmitted on the falling edge of SCLK. Each time slot is 32 bits wide, with the valid data sample left ‘justified within the time slot. Valid data lengths are 16, 18, 20, or 24.

SCLK must operate at 256Fs. FS identifies the start of a new frame and is equal to the sample rate,  $F_s$ .

FS is sampled as valid on the rising SCLK edge preceding the most significant bit of the first data sample and must be held valid for at least 1 SCLK period.

**Note:** The ADC does not meet the timing requirements for proper operation in Quad-Speed Mode.



**Figure 13. TDM Serial Audio Format**

### 5.5.2 I/O Channel Allocation

| Digital Input/Output | Interface Format | Analog Output/Input Channel Allocation from/to Digital I/O |
|----------------------|------------------|--|
| DAC_SDIN             | TDM              | AOUT 1,2,3,4,5,6   |
| ADC_SDOUT            | TDM              | AIN 1,2,3,4 (2 additional channels from AUX_SDIN)          |

**Table 4. Serial Audio Interface Channel Allocations**

## 5.6 AUX Port Digital Interface Formats

These serial data lines are used when supporting the TDM Mode of operation with an external ADC or S/PDIF receiver attached. The AUX serial port operates only as a clock master. The AUX\_SCLK will operate at 64xFs, where Fs is equal to the ADC sample rate (FS on the TDM interface). If the AUX\_SDIN signal is not being used, it should be tied to AGND via a pull-down resistor.

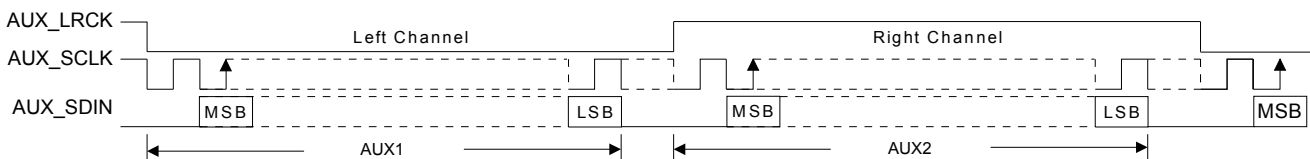
### 5.6.1 Hardware Mode

The AUX port will only operate in the Left-Justified digital interface format and supports bit depths ranging from 16 to 24 bits (see [Figure 17 on page 34](#) for timing relationship between AUX\_LRCK and AUX\_SCLK).

### 5.6.2 Software Mode

The AUX port will operate in either the Left-Justified or I<sup>2</sup>S digital interface format with bit depths ranging from 16 to 24 bits. Settings for the AUX port are made through the register “[Miscellaneous Control \(Address 04h\)](#)” on [page 41](#).

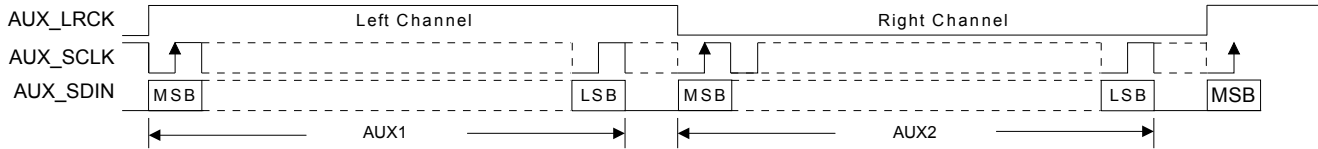
### 5.6.3 I<sup>2</sup>S



**Figure 14. AUX I<sup>2</sup>S Format**



### 5.6.4 Left-Justified



**Figure 15. AUX Left-Justified Format**

## 5.7 Control Port Description and Timing

The control port is used to access the registers, in Software Mode, allowing the CS42432 to be configured for the desired operational modes and formats. The operation of the control port may be completely asynchronous with respect to the audio sample rates. However, to avoid potential interference problems, the control port pins should remain static if no operation is required.

The control port has two modes: SPI and I<sup>2</sup>C, with the CS42432 acting as a slave device. SPI Mode is selected if there is a high-to-low transition on the AD0/ $\overline{\text{CS}}$  pin, after the RST pin has been brought high. I<sup>2</sup>C Mode is selected by connecting the AD0/ $\overline{\text{CS}}$  pin through a resistor to VLC or DGND, thereby permanently selecting the desired AD0 bit address state.

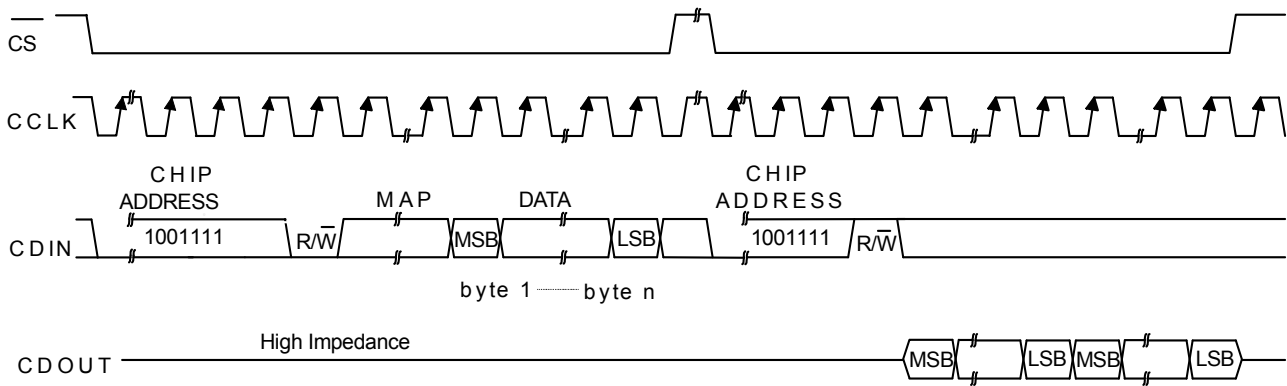
### 5.7.1 SPI Mode

In SPI Mode,  $\overline{\text{CS}}$  is the CS42432 chip-select signal, CCLK is the control port bit clock (input into the CS42432 from the microcontroller), CDIN is the input data line from the microcontroller, CDOUT is the output data line to the microcontroller. Data is clocked in on the rising edge of CCLK and out on the falling edge.

Figure 16 shows the operation of the control port in SPI Mode. To write to a register, bring  $\overline{\text{CS}}$  low. The first seven bits on CDIN form the chip address and must be 1001111. The eighth bit is a read/write indicator (R/W), which should be low to write. The next eight bits form the Memory Address Pointer (MAP), which is set to the address of the register that is to be updated. The next eight bits are the data which will be placed into the register designated by the MAP. During writes, the CDOUT output stays in the Hi-Z state. It may be externally pulled high or low with a 47 k $\Omega$  resistor, if desired.

There is a MAP auto-increment capability, enabled by the INCR bit in the MAP register. If INCR is a zero, the MAP will stay constant for successive read or writes. If INCR is set to a 1, the MAP will auto-increment after each byte is read or written, allowing block reads or writes of successive registers.

To read a register, the MAP has to be set to the correct address by executing a partial write cycle which finishes ( $\overline{\text{CS}}$  high) immediately after the MAP byte. The MAP auto-increment bit (INCR) may be set or not, as desired. To begin a read, bring  $\overline{\text{CS}}$  low, send out the chip address and set the read/write bit (R/W) high. The next falling edge of CCLK will clock out the MSB of the addressed register (CDOUT will leave the high impedance state). If the MAP auto-increment bit is set to 1, the data for successive registers will appear consecutively.



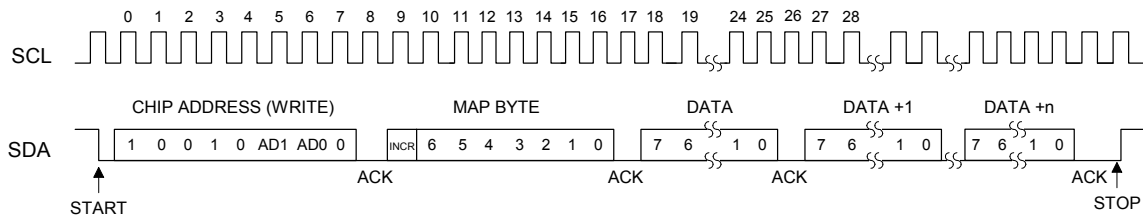
MAP = Memory Address Pointer, 8 bits, MSB first

**Figure 16. Control Port Timing in SPI Mode**

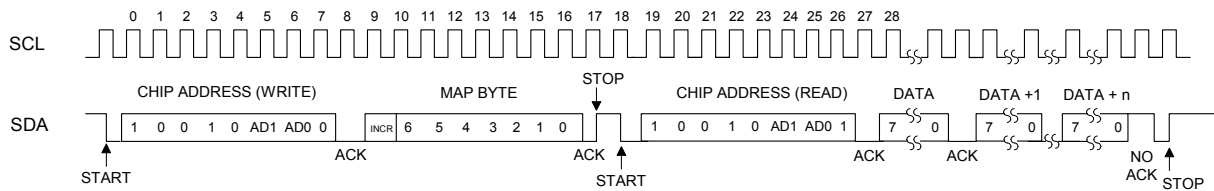
### 5.7.2 I<sup>2</sup>C Mode

In I<sup>2</sup>C Mode, SDA is a bidirectional data line. Data is clocked into and out of the part by the clock, SCL. There is no CS pin. Pins AD0 and AD1 form the two least-significant bits of the chip address and should be connected through a resistor to VLC or DGND as desired. The state of the pins is sensed while the CS42432 is being reset.

The signal timings for a read and write cycle are shown in [Figure 17](#) and [Figure 18](#). A Start condition is defined as a falling transition of SDA while the clock is high. A Stop condition is a rising transition while the clock is high. All other transitions of SDA occur while the clock is low. The first byte sent to the CS42432 after a Start condition consists of a 7-bit chip address field and a R/W bit (high for a read, low for a write). The upper 5 bits of the 7-bit address field are fixed at 10010. To communicate with a CS42432, the chip address field, which is the first byte sent to the CS42432, should match 10010 followed by the settings of the AD1 and AD0. The eighth bit of the address is the R/W bit. If the operation is a write, the next byte is the Memory Address Pointer (MAP) which selects the register to be read or written. If the operation is a read, the contents of the register pointed to by the MAP will be output. Setting the auto-increment bit in MAP allows successive reads or writes of consecutive registers. Each byte is separated by an acknowledge bit. The ACK bit is output from the CS42432 after each input byte is read, and is input to the CS42432 from the microcontroller after each transmitted byte.



**Figure 17. Control Port Timing, I<sup>2</sup>C Write**



**Figure 18. Control Port Timing, I<sup>2</sup>C Read**

Since the read operation cannot set the MAP, an aborted write operation is used as a preamble. As shown in [Figure 18](#), the write operation is aborted after the acknowledge for the MAP byte by sending a stop condition. The following pseudocode illustrates an aborted write operation followed by a read operation.

Send start condition.

Send 10010xx0 (chip address & write operation).

Receive acknowledge bit.

Send MAP byte, auto increment off.

Receive acknowledge bit.

Send stop condition, aborting write.

Send start condition.

Send 10010xx1(chip address & read operation).

Receive acknowledge bit.

Receive byte, contents of selected register.

Send acknowledge bit.

Send stop condition.

Setting the auto-increment bit in the MAP allows successive reads or writes of consecutive registers. Each byte is separated by an acknowledge bit.

## 5.8 Recommended Power-Up Sequence

### 5.8.1 Hardware Mode

1. Hold  $\overline{\text{RST}}$  low until the power supply, clocks and hardware control pins are stable. In this state, the control port is reset to its default settings and VQ will remain low.
2. Bring  $\overline{\text{RST}}$  high. The device will initially be in a low power state with VQ low.
3. The device will initiate the Hardware Mode power up sequence. All features will default to the Hardware Mode defaults as listed in [Table 2 on page 26](#) according to the Hardware Mode control pins. VQ will quick-charge to approximately VA/2 and the analog output bias will clamp to VQ.
4. Following approximately 2000 sample periods, the device is initialized and ready for normal operation.

**Note:** During the Hardware Mode power-up sequence, there must be no transitions on any of the hardware control pins.

### 5.8.2 Software Mode

1. Hold  $\overline{\text{RST}}$  low until the power supply and clocks are stable. In this state, the control port is reset to its default settings and VQ will remain low.
2. Bring  $\overline{\text{RST}}$  high. The device will initially be in a low power state with VQ low. All features will default as described in the “[Register Quick Reference](#)” on page 37.
3. Perform a write operation to the Power Control register (“[Power Control \(Address 02h\)](#)” on page 40) to set bit 0 to a ‘1’b. This will place the device in a power down state.
4. Load the desired register settings while keeping the PDN bit set to ‘1’b.
5. Mute all DACs. Muting the DACs suppresses any noise associated with the CODEC’s first initialization after power is applied.
6. Set the PDN bit in the power control register to ‘0’b. Following approximately 2000 LRCK cycles, the device is initialized and ready for normal operation.
7. After the CODEC is initialized, wait ~90 LRCK cycles (~1.9 ms @48 kHz) and then unmute the DACs.
8. Normal operation begins.

### 5.9 Reset and Power-Up

It is recommended that reset be activated if the analog or digital supplies drop below the recommended operating condition to prevent power-glitch-related issues.

The delta-sigma modulators settle in a matter of microseconds after the analog section is powered, either through the application of power or by setting the  $\overline{\text{RST}}$  pin high. However, the voltage reference will take much longer to reach a final value due to the presence of external capacitance on the FILT+ pin. A time delay of approximately 400 ms is required after applying power to the device or after exiting a reset state. During this voltage reference ramp delay, all serial ports and DAC outputs will be automatically muted.

### 5.10 Power Supply, Grounding, and PCB Layout

As with any high-resolution converter, the CS42432 requires careful attention to power supply and grounding arrangements if its potential performance is to be realized. [1](#) and [2](#) show the recommended power arrangements, with VA connected to clean supplies. VD, which powers the digital circuitry, may be run from the system logic supply.

Extensive use of power and ground planes, ground plane fill in unused areas and surface mount decoupling capacitors are recommended. Decoupling capacitors should be as near to the pins of the CS42432 as possible. The low value ceramic capacitor should be the nearest to the pin and should be mounted on the same side of the board as the CS42432 to minimize inductance effects. All signals, especially clocks, should be kept away from the FILT+, VQ pins in order to avoid unwanted coupling into the modulators. The FILT+ and VQ decoupling capacitors, particularly the 0.1  $\mu\text{F}$ , must be positioned to minimize the electrical path from FILT+ and AGND. The CS42432 evaluation board demonstrates the optimum layout and power supply arrangements.

For optimal heat dissipation from the package, it is recommended that the area directly under the part be filled with copper and tied to the ground plane. The use of vias connecting the topside ground to the backside ground is also recommended.

## 6. REGISTER QUICK REFERENCE

Software Mode register defaults are as shown. **Note:** The default value in all “Reserved” registers must be preserved.

| Addr | Function                                | 7                      | 6               | 5               | 4                | 3                | 2                | 1               | 0               |
|------|---|------------------------|-----------------|-----------------|------------------|------------------|------------------|-----------------|-----------------|
| 01h  | ID<br>p 39 default                      | Chip_ID3<br>0          | Chip_ID2<br>0   | Chip_ID1<br>0   | Chip_ID0<br>0    | Rev_ID3<br>0     | Rev_ID2<br>0     | Rev_ID1<br>0    | Rev_ID0<br>1    |
| 02h  | Power Control<br>p 40 default           | Reserved<br>0          | PDN_ADC2<br>0   | PDN_ADC1<br>0   | Reserved<br>0    | PDN_DAC3<br>0    | PDN_DAC2<br>0    | PDN_DAC1<br>0   | PDN<br>0        |
| 03h  | Functional Mode<br>p 41 default         | Reserved<br>1          | Reserved<br>1   | Reserved<br>1   | Reserved<br>1    | MFreq2<br>0      | MFreq1<br>0      | MFreq0<br>0     | Reserved<br>0   |
| 04h  | Misc Control<br>p 41 default            | FREEZE<br>0            | AUX_DIF<br>0    | Reserved<br>1   | Reserved<br>1    | Reserved<br>0    | Reserved<br>1    | Reserved<br>1   | Reserved<br>0   |
| 05h  | ADC Control (w/DAC_DEM)<br>p 42 default | ADC1-2_HPF FREEZE<br>0 | Reserved<br>0   | DAC_DEM<br>0    | ADC1 SINGLE<br>0 | ADC2 SINGLE<br>0 | Reserved<br>0    | Reserved<br>0   | Reserved<br>0   |
| 06h  | Transition Control<br>p 43 default      | DAC_SNG VOL<br>0       | DAC_SZC1<br>0   | DAC_SZC0<br>0   | AMUTE<br>1       | MUTE ADC_SP<br>0 | ADC_SNG VOL<br>0 | ADC_SZC1<br>0   | ADC_SZC0<br>0   |
| 07h  | Channel Mute<br>p 44 default            | Reserved<br>0          | Reserved<br>0   | AOUT6 MUTE<br>0 | AOUT5 MUTE<br>0  | AOUT4 MUTE<br>0  | AOUT3 MUTE<br>0  | AOUT2 MUTE<br>0 | AOUT1 MUTE<br>0 |
| 08h  | Vol. Control AOUT1<br>p 45 default      | AOUT1 VOL7<br>0        | AOUT1 VOL6<br>0 | AOUT1 VOL5<br>0 | AOUT1 VOL4<br>0  | AOUT1 VOL3<br>0  | AOUT1 VOL2<br>0  | AOUT1 VOL1<br>0 | AOUT1 VOL0<br>0 |
| 09h  | Vol. Control AOUT2<br>p 45 default      | AOUT2 VOL7<br>0        | AOUT2 VOL6<br>0 | AOUT2 VOL5<br>0 | AOUT2 VOL4<br>0  | AOUT2 VOL3<br>0  | AOUT2 VOL2<br>0  | AOUT2 VOL1<br>0 | AOUT2 VOL0<br>0 |
| 0Ah  | Vol. Control AOUT3<br>p 45 default      | AOUT3 VOL7<br>0        | AOUT3 VOL6<br>0 | AOUT3 VOL5<br>0 | AOUT3 VOL4<br>0  | AOUT3 VOL3<br>0  | AOUT3 VOL2<br>0  | AOUT3 VOL1<br>0 | AOUT3 VOL0<br>0 |
| 0Bh  | Vol. Control AOUT4<br>p 45 default      | AOUT4 VOL7<br>0        | AOUT4 VOL6<br>0 | AOUT4 VOL5<br>0 | AOUT4 VOL4<br>0  | AOUT4 VOL3<br>0  | AOUT4 VOL2<br>0  | AOUT4 VOL1<br>0 | AOUT4 VOL0<br>0 |
| 0Ch  | Vol. Control AOUT5<br>p 45 default      | AOUT5 VOL7<br>0        | AOUT5 VOL6<br>0 | AOUT5 VOL5<br>0 | AOUT5 VOL4<br>0  | AOUT5 VOL3<br>0  | AOUT5 VOL2<br>0  | AOUT5 VOL1<br>0 | AOUT5 VOL0<br>0 |
| 0Dh  | Vol. Control AOUT6<br>p 45 default      | AOUT6 VOL7<br>0        | AOUT6 VOL6<br>0 | AOUT6 VOL5<br>0 | AOUT6 VOL4<br>0  | AOUT6 VOL3<br>0  | AOUT6 VOL2<br>0  | AOUT6 VOL1<br>0 | AOUT6 VOL0<br>0 |
| 0Eh  | Reserved<br>default                     | Reserved<br>0          | Reserved<br>0   | Reserved<br>0   | Reserved<br>0    | Reserved<br>0    | Reserved<br>0    | Reserved<br>0   | Reserved<br>0   |
| 0Fh  | Reserved<br>default                     | Reserved<br>0          | Reserved<br>0   | Reserved<br>0   | Reserved<br>0    | Reserved<br>0    | Reserved<br>0    | Reserved<br>0   | Reserved<br>0   |
| 10h  | DAC Channel Invert<br>p 45 default      | Reserved<br>0          | Reserved<br>0   | INV_AOUT6<br>0  | INV_AOUT5<br>0   | INV_AOUT4<br>0   | INV_AOUT3<br>0   | INV_AOUT2<br>0  | INV_AOUT1<br>0  |

| Addr | Function                                | 7                 | 6                 | 5                 | 4                 | 3                   | 2                 | 1                   | 0                   |
|------|---|-------------------|-------------------|-------------------|-------------------|---------------------|-------------------|---------------------|---------------------|
| 11h  | Vol. Control<br>AIN1<br>p 45 default    | AIN1<br>VOL7<br>0 | AIN1<br>VOL6<br>0 | AIN1<br>VOL5<br>0 | AIN1<br>VOL4<br>0 | AIN1<br>VOL3<br>0   | AIN1<br>VOL2<br>0 | AIN1<br>VOL1<br>0   | AIN1<br>VOL0<br>0   |
| 12h  | Vol. Control<br>AIN2<br>p 45 default    | AIN2<br>VOL7<br>0 | AIN2<br>VOL6<br>0 | AIN2<br>VOL5<br>0 | AIN2<br>VOL4<br>0 | AIN2<br>VOL3<br>0   | AIN2<br>VOL2<br>0 | AIN2<br>VOL1<br>0   | AIN2<br>VOL0<br>0   |
| 13h  | Vol. Control<br>AIN3<br>p 45 default    | AIN3<br>VOL7<br>0 | AIN3<br>VOL6<br>0 | AIN3<br>VOL5<br>0 | AIN3<br>VOL4<br>0 | AIN3<br>VOL3<br>0   | AIN3<br>VOL2<br>0 | AIN3<br>VOL1<br>0   | AIN3<br>VOL0<br>0   |
| 14h  | Vol. Control<br>AIN4<br>p 45 default    | AIN4<br>VOL7<br>0 | AIN4<br>VOL6<br>0 | AIN4<br>VOL5<br>0 | AIN4<br>VOL4<br>0 | AIN4<br>VOL3<br>0   | AIN4<br>VOL2<br>0 | AIN4<br>VOL1<br>0   | AIN4<br>VOL0<br>0   |
| 15h  | Reserved<br>default                     | Reserved<br>0     | Reserved<br>0     | Reserved<br>0     | Reserved<br>0     | Reserved<br>0       | Reserved<br>0     | Reserved<br>0       | Reserved<br>0       |
| 16h  | Reserved<br>default                     | Reserved<br>0     | Reserved<br>0     | Reserved<br>0     | Reserved<br>0     | Reserved<br>0       | Reserved<br>0     | Reserved<br>0       | Reserved<br>0       |
| 17h  | ADC Chan-<br>nel Invert<br>p 45 default | Reserved<br>0     | Reserved<br>0     | Reserved<br>0     | Reserved<br>0     | INV_A4<br>0         | INV_A3<br>0       | INV_A2<br>0         | INV_A1<br>0         |
| 18h  | Reserved<br>default                     | Reserved<br>0     | Reserved<br>0     | Reserved<br>0     | Reserved<br>0     | Reserved<br>0       | Reserved<br>0     | Reserved<br>0       | Reserved<br>0       |
| 19h  | Status<br>p 46 default                  | Reserved<br>0     | Reserved<br>0     | Reserved<br>0     | Reserved<br>X     | CLK<br>Error<br>X   | Reserved<br>X     | ADC2<br>OVFL<br>X   | ADC1<br>OVFL<br>X   |
| 1Ah  | Status Mask<br>p 47 default             | Reserved<br>0     | Reserved<br>0     | Reserved<br>0     | Reserved<br>0     | CLK<br>Error_M<br>0 | Reserved<br>0     | ADC2<br>OVFL_M<br>0 | ADC1<br>OVFL_M<br>0 |

## 7. REGISTER DESCRIPTION

All registers are read/write except for the I.D. and Revision Register and Interrupt Status Register which are read only. See the following bit-definition tables for bit assignment information. The default state of each bit after a power-up sequence or reset is listed in each bit description.

### 7.1 Memory Address Pointer (MAP)

Not a register

|          |          |          |          |          |          |          |          |
|----------|----------|----------|----------|----------|----------|----------|----------|
| <b>7</b> | <b>6</b> | <b>5</b> | <b>4</b> | <b>3</b> | <b>2</b> | <b>1</b> | <b>0</b> |
| INCR     | MAP6     | MAP5     | MAP4     | MAP3     | MAP2     | MAP1     | MAP0     |

#### 7.1.1 Increment (INCR)

Default = 1

Function:

Memory address pointer auto increment control

0 - MAP is not incremented automatically.

1 - Internal MAP is automatically incremented after each read or write.

#### 7.1.2 Memory Address Pointer (MAP[6:0])

Default = 0000001

Function:

Memory address pointer (MAP). Sets the register address that will be read or written by the control port.

### 7.2 Chip I.D. and Revision Register (Address 01h) (Read Only)

|          |          |          |          |          |          |          |          |
|----------|----------|----------|----------|----------|----------|----------|----------|
| <b>7</b> | <b>6</b> | <b>5</b> | <b>4</b> | <b>3</b> | <b>2</b> | <b>1</b> | <b>0</b> |
| Chip_ID3 | Chip_ID2 | Chip_ID1 | Chip_ID0 | Rev_ID3  | Rev_ID2  | Rev_ID1  | Rev_ID0  |

#### 7.2.1 Chip I.D. (CHIP\_ID[3:0])

Default = 0000

Function:

I.D. code for the CS42432. Permanently set to 0000.

#### 7.2.2 Chip Revision (REV\_ID[3:0])

Default = 0001

Function:

CS42432 revision level. Revision A is coded as 0001.

### 7.3 Power Control (Address 02h)

|          |          |          |          |          |          |          |     |
|----------|----------|----------|----------|----------|----------|----------|-----|
| 7        | 6        | 5        | 4        | 3        | 2        | 1        | 0   |
| Reserved | PDN_ADC2 | PDN_ADC1 | Reserved | PDN_DAC3 | PDN_DAC2 | PDN_DAC1 | PDN |

#### 7.3.1 Power Down ADC Pairs (PDN\_ADCX)

Default = 0

0 - Disable

1 - Enable

Function:

When enabled, the respective ADC channel pair (ADC1 - AIN1/AIN2; and ADC2 - AIN3/AIN4) will remain in a reset state.

#### 7.3.2 Power Down DAC Pairs (PDN\_DACX)

Default = 0

0 - Disable

1 - Enable

Function:

When enabled, the respective DAC channel pair (DAC1 - AOUT1/AOUT2; DAC2 - AOUT3/AOUT4; and DAC3 - AOUT5/AOUT6) will remain in a reset state. It is advised that any change of these bits be made while the DACs are muted or the power down bit (PDN) is enabled to eliminate the possibility of audible artifacts.

#### 7.3.3 Power Down (PDN)

Default = 0

0 - Disable

1 - Enable

Function:

The entire device will enter a low-power state when this function is enabled. The contents of the control registers are retained in this mode.



## 7.4 Functional Mode (Address 03h)

|          |          |          |          |        |        |        |          |
|----------|----------|----------|----------|--------|--------|--------|----------|
| 7        | 6        | 5        | 4        | 3      | 2      | 1      | 0        |
| Reserved | Reserved | Reserved | Reserved | MFreq2 | MFreq1 | MFreq0 | Reserved |

### 7.4.1 MCLK Frequency (MFREQ[2:0])

Default = 000

Function:

Sets the appropriate frequency for the supplied MCLK. For TDM operation, SCLK must equal 256Fs. MCLK can be equal to or greater than SCLK.

|        |        |        |                           | Ratio (xFs) |     |     |
|--------|--------|--------|---------------------------|-------------|-----|-----|
| MFreq2 | MFreq1 | MFreq0 | Description               | SSM         | DSM | QSM |
| 0      | 0      | 0      | 1.0290 MHz to 12.8000 MHz | 256         | N/A | N/A |
| 0      | 0      | 1      | Reserved                  |             |     |     |
| 0      | 1      | 0      | 2.0480 MHz to 25.6000 MHz | 512         | 256 | N/A |
| 0      | 1      | 1      | Reserved                  |             |     |     |
| 1      | X      | X      | 4.0960 MHz to 51.2000 MHz | 1024        | 512 | 256 |

Table 5. MCLK Frequency Settings

## 7.5 MISCELLANEOUS CONTROL (Address 04h)

|        |         |          |          |          |          |          |          |
|--------|---------|----------|----------|----------|----------|----------|----------|
| 7      | 6       | 5        | 4        | 3        | 2        | 1        | 0        |
| FREEZE | AUX_DIF | Reserved | Reserved | Reserved | Reserved | Reserved | Reserved |

### 7.5.1 Freeze Controls (FREEZE)

Default = 0

Function:

This function will freeze the previous settings of, and allow modifications to be made to the channel mutes, the DAC and ADC Volume Control/Channel Invert registers without the changes taking effect until the FREEZE is disabled. To have multiple changes in these control port registers take effect simultaneously, enable the FREEZE bit, make all register changes, then disable the FREEZE bit.

### 7.5.2 Auxiliary Digital Interface Format (AUX\_DIF)

Default = 0

0 - Left Justified  
1 - I<sup>2</sup>S

Function:

This bit selects the digital interface format used for the AUX Serial Port. The required relationship between the Left/Right clock, serial clock and serial data is defined by the Digital Interface Format and the options are detailed in [Figures 16-17](#).

## 7.6 ADC Control & DAC De-Emphasis (Address 05h)

| 7                   | 6        | 5       | 4              | 3              | 2        | 1        | 0        |
|---------------------|----------|---------|----------------|----------------|----------|----------|----------|
| ADC1-2_HP<br>FREEZE | Reserved | DAC_DEM | ADC1<br>SINGLE | ADC2<br>SINGLE | Reserved | Reserved | Reserved |

### 7.6.1 ADC1-2 High-Pass Filter Freeze (ADC1-2\_HP FREEZE)

Default = 0

Function:

When this bit is set, the internal high-pass filter will be disabled for ADC1 and ADC2. The current DC offset value will be frozen and continue to be subtracted from the conversion result. See [“ADC Digital Filter Characteristics” on page 16](#).

### 7.6.2 DAC De-Emphasis Control (DAC\_DEM)

Default = 0

0 - No De-Emphasis

1 - De-Emphasis Enabled (Auto-Detect Fs)

Function:

Enables the digital filter to maintain the standard 15 $\mu$ s/50 $\mu$ s digital de-emphasis filter response at the auto-detected sample rate of either 32, 44.1, or 48 kHz. De-emphasis will not be enabled, regardless of this register setting, at any other sample rate.

### 7.6.3 ADC1 Single-Ended Mode (ADC1 SINGLE)

Default = 0

0 - Disabled; Differential input to ADC1

1 - Enabled; Single-Ended input to ADC1

Function:

When enabled, this bit allows the user to apply a single-ended input to the positive terminal of ADC1. A +6 dB digital gain is automatically applied to the serial audio data of ADC1. The negative leg must be driven to the common mode of the ADC. See [Figure 20 on page 48](#) for a graphical description.

### 7.6.4 ADC2 Single-Ended Mode (ADC2 SINGLE)

Default = 0

- 0 - Disabled; Differential input to ADC2
- 1 - Enabled; Single-Ended input to ADC2

Function:

When enabled, this bit allows the user to apply a single-ended input to the positive terminal of ADC2. A +6 dB digital gain is automatically applied to the serial audio data of ADC2. The negative leg must be driven to the common mode of the ADC. See [Figure 20 on page 48](#) for a graphical description.

## 7.7 Transition Control (Address 06h)

| 7          | 6        | 5        | 4     | 3           | 2          | 1        | 0        |
|------------|----------|----------|-------|-------------|------------|----------|----------|
| DAC_SNGVOL | DAC_SZC1 | DAC_SZC0 | AMUTE | MUTE ADC_SP | ADC_SNGVOL | ADC_SZC1 | ADC_SZC0 |

### 7.7.1 Single Volume Control (DAC\_SNGVOL, ADC\_SNGVOL)

Default = 0

Function:

The individual channel volume levels are independently controlled by their respective Volume Control registers when this function is disabled. When enabled, the volume on all channels is determined by the AOUT1 and AIN1 Volume Control register and the other Volume Control registers are ignored.

### 7.7.2 Soft Ramp and Zero Cross Control (ADC\_SZC[1:0], DAC\_SZC[1:0])

Default = 00

- 00 - Immediate Change
- 01 - Zero Cross
- 10 - Soft Ramp
- 11 - Soft Ramp on Zero Crossings

Function:

#### Immediate Change

When Immediate Change is selected, all volume-level changes will take effect immediately in one step.

#### Zero Cross

Zero Cross Enable dictates that signal level changes, either by gain changes, attenuation changes or muting, will occur on a signal zero crossing to minimize audible artifacts. The requested level change will occur after a timeout period between 512 and 1024 sample periods (10.7 ms to 21.3 ms at 48 kHz sample rate) if the signal does not encounter a zero crossing. The zero cross function is independently monitored and implemented for each channel.

#### Soft Ramp

Soft Ramp allows level changes, either by gain changes, attenuation changes or muting, to be implemented by incrementally ramping, in 1/8 dB steps, from the current level to the new level at a rate of 1 dB per 8 left/right clock periods.

### Soft Ramp on Zero Crossing

Soft Ramp and Zero Cross Enable dictates that signal level changes, either by gain changes, attenuation changes or muting, will occur in 1/8 dB steps and be implemented on a signal zero crossing. The 1/8 dB level change will occur after a timeout period between 512 and 1024 sample periods (10.7 ms to 21.3 ms at 48 kHz sample rate) if the signal does not encounter a zero crossing. The zero cross function is independently monitored and implemented for each channel.

#### **7.7.3 Auto-Mute (AMUTE)**

Default = 1

0 - Disabled

1 - Enabled

Function:

The Digital-to-Analog converters of the CS42432 will mute the output following the reception of 8192 consecutive audio samples of static 0 or -1. A single sample of non-static data will release the mute. Detection and muting is done independently for each channel. The quiescent voltage on the output will be retained during the mute period. The muting function is affected, similar to volume control changes, by the Soft and Zero Cross bits (SZC[1:0]).

#### **7.7.4 Mute ADC Serial Port (MUTE\_ADC\_SP)**

Default = 0

0 - Disabled

1 - Enabled

Function:

When enabled, the ADC Serial Port will be muted.

### **7.8 DAC Channel Mute (Address 07h)**

|          |          |            |            |            |            |            |            |
|----------|----------|------------|------------|------------|------------|------------|------------|
| 7        | 6        | 5          | 4          | 3          | 2          | 1          | 0          |
| Reserved | Reserved | AOUT6_MUTE | AOUT5_MUTE | AOUT4_MUTE | AOUT3_MUTE | AOUT2_MUTE | AOUT1_MUTE |

#### **7.8.1 Independent Channel Mute (AOUTX\_MUTE)**

Default = 0

0 - Disabled

1 - Enabled

Function:

The respective Digital-to-Analog converter outputs of the CS42432 will mute when enabled. The quiescent voltage on the outputs will be retained. The muting function is affected by the DAC Soft and Zero Cross bits (DAC\_SZC[1:0]).

## 7.9 AOUTX Volume Control (Addresses 08h-0D)

|            |            |            |            |            |            |            |            |
|------------|------------|------------|------------|------------|------------|------------|------------|
| 7          | 6          | 5          | 4          | 3          | 2          | 1          | 0          |
| AOUTx_VOL7 | AOUTx_VOL6 | AOUTx_VOL5 | AOUTx_VOL4 | AOUTx_VOL3 | AOUTx_VOL2 | AOUTx_VOL1 | AOUTx_VOL0 |

### 7.9.1 Volume Control (AOUTX\_VOL[7:0])

Default = 00h

Function:

The AOUTx Volume Control registers allow independent setting of the signal levels in 0.5 dB increments from 0 dB to -127.5 dB. Volume settings are decoded as shown in [Table 6](#). The volume changes are implemented as dictated by the Soft and Zero Cross bits (DAC\_SZC[1:0]). All volume settings less than -127.5 dB are equivalent to enabling the AOUTx\_MUTE bit for the given channel.

| Binary Code | Volume Setting |
|-------------|----------------|
| 00000000    | 0 dB           |
| 00101000    | -20 dB         |
| 01010000    | -40 dB         |
| 01111000    | -60 dB         |
| 10110100    | -90 dB         |

**Table 6. Example AOUT Volume Settings**

## 7.10 DAC Channel Invert (Address 10h)

|          |          |           |           |           |           |           |           |
|----------|----------|-----------|-----------|-----------|-----------|-----------|-----------|
| 7        | 6        | 5         | 4         | 3         | 2         | 1         | 0         |
| Reserved | Reserved | INV_AOUT6 | INV_AOUT5 | INV_AOUT4 | INV_AOUT3 | INV_AOUT2 | INV_AOUT1 |

### 7.10.1 Invert Signal Polarity (INV\_AOUTX)

Default = 0

0 - Disabled

1 - Enabled

Function:

When enabled, these bits will invert the signal polarity of their respective channels.

## 7.11 AINX Volume Control (Address 11h-14h)

|           |           |           |           |           |           |           |           |
|-----------|-----------|-----------|-----------|-----------|-----------|-----------|-----------|
| 7         | 6         | 5         | 4         | 3         | 2         | 1         | 0         |
| AINx_VOL7 | AINx_VOL6 | AINx_VOL5 | AINx_VOL4 | AINx_VOL3 | AINx_VOL2 | AINx_VOL1 | AINx_VOL0 |

### 7.11.1 AINX Volume Control (AINX\_VOL[7:0])

Default = 00h

Function:

The level of AIN1 - AIN6 can be adjusted in 0.5 dB increments as dictated by the ADC Soft and Zero Cross bits (ADC\_SZC[1:0]) from +24 to -64 dB. Levels are decoded in two's complement, as shown in [Table 7](#).

| Binary Code | Volume Setting |
|-------------|----------------|
| 0111 1111   | +24 dB         |
| ...         | ...            |
| 0011 0000   | +24 dB         |
| ...         | ...            |
| 0000 0000   | 0 dB           |
| 1111 1111   | -0.5 dB        |
| 1111 1110   | -1 dB          |
| ...         | ...            |
| 1000 0000   | -64 dB         |

**Table 7. Example AIN Volume Settings**

## 7.12 ADC Channel Invert (Address 17h)

| 7        | 6        | 5        | 4        | 3        | 2        | 1        | 0        |
|----------|----------|----------|----------|----------|----------|----------|----------|
| Reserved | Reserved | Reserved | Reserved | INV_AIN4 | INV_AIN3 | INV_AIN2 | INV_AIN1 |

### 7.12.1 Invert Signal Polarity (INV\_AINX)

Default = 0

0 - Disabled

1 - Enabled

Function:

When enabled, these bits will invert the signal polarity of their respective channels.

## 7.13 Status (Address 19h) (Read Only)

| 7        | 6        | 5        | 4        | 3         | 2        | 1         | 0         |
|----------|----------|----------|----------|-----------|----------|-----------|-----------|
| Reserved | Reserved | Reserved | Reserved | CLK Error | Reserved | ADC2_OVFL | ADC1_OVFL |

For all bits in this register, a “1” means the associated error condition has occurred at least once since the register was last read. A “0” means the associated error condition has NOT occurred since the last reading of the register. Reading the register resets all bits to 0. Status bits that are masked off in the associated mask register will always be “0” in this register.

### 7.13.1 Clock Error (CLK ERROR)

Default = x

Function:

Indicates an invalid MCLK to FS ratio. This status flag is set to “Level Active Mode” and becomes active during the error condition. See [“System Clocking” on page 31](#) for valid clock ratios.

### 7.13.2 ADC Overflow (ADCX\_OVFL)

Default = x

Function:

Indicates that there is an over-range condition anywhere in the CS42432 ADC signal path of each of the associated ADC’s.

---

### 7.14 Status Mask (Address 1Ah)

| 7        | 6        | 5        | 4        | 3           | 2        | 1           | 0           |
|----------|----------|----------|----------|-------------|----------|-------------|-------------|
| Reserved | Reserved | Reserved | Reserved | CLK Error_M | Reserved | ADC2_OVFL_M | ADC1_OVFL_M |

Default = 0000

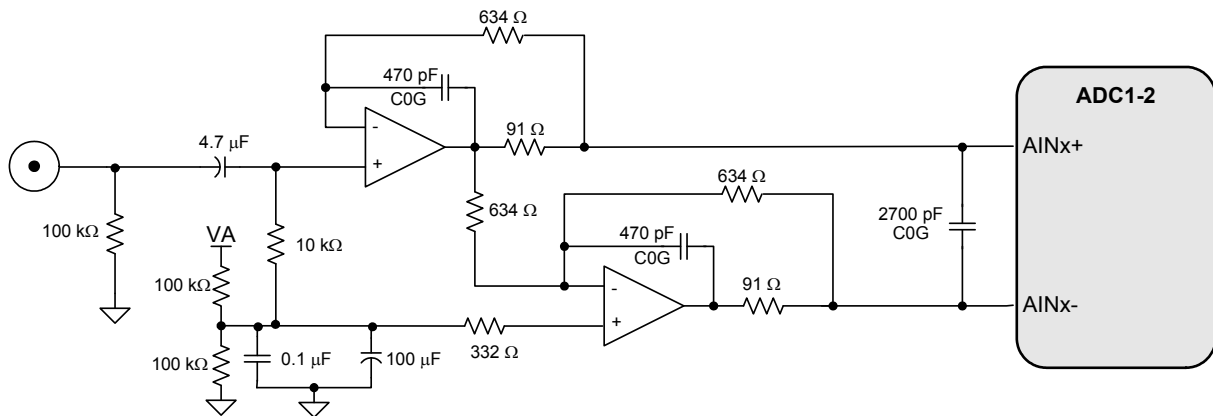
Function:

The bits of this register serve as a mask for the error sources found in the register [“Status \(Address 19h\) \(Read Only\)” on page 46](#). If a mask bit is set to 1, the error is unmasked, meaning that its occurrence will affect the status register. If a mask bit is set to 0, the error is masked, meaning that its occurrence will not affect status register. The bit positions align with the corresponding bits in the Status register.

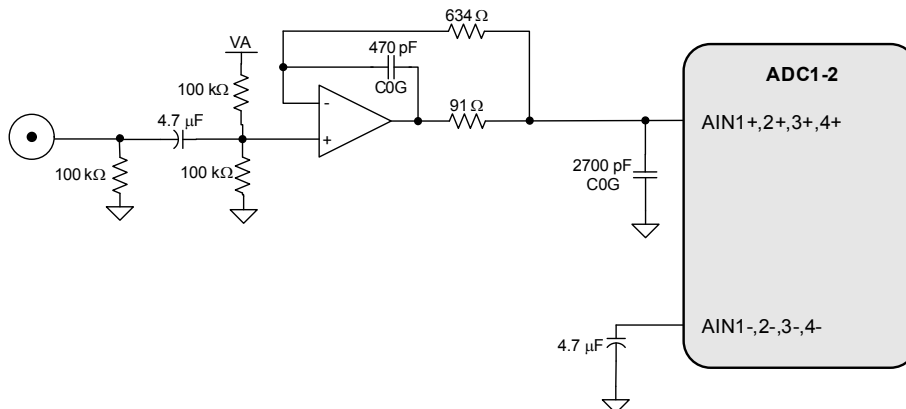
## 8. EXTERNAL FILTERS

### 8.1 ADC Input Filter

The analog modulator samples the input at 6.144 MHz (internal MCLK=12.288 MHz). The digital filter will reject signals within the stopband of the filter. However, there is no rejection for input signals which are multiples of the digital passband frequency ( $n \times 6.144$  MHz), where  $n=0,1,2,\dots$ . Refer to [Figures 19 and 20](#) for a recommended analog input filter that will attenuate any noise energy at 6.144 MHz, in addition to providing the optimum source impedance for the modulators. Refer to [Figures 21 and 22](#) for low-cost, low-component-count passive input filters. The use of capacitors that have a large voltage coefficient (such as general-purpose ceramics) must be avoided since these can degrade signal linearity



**Figure 19. Single-to-Differential Active Input Filter**

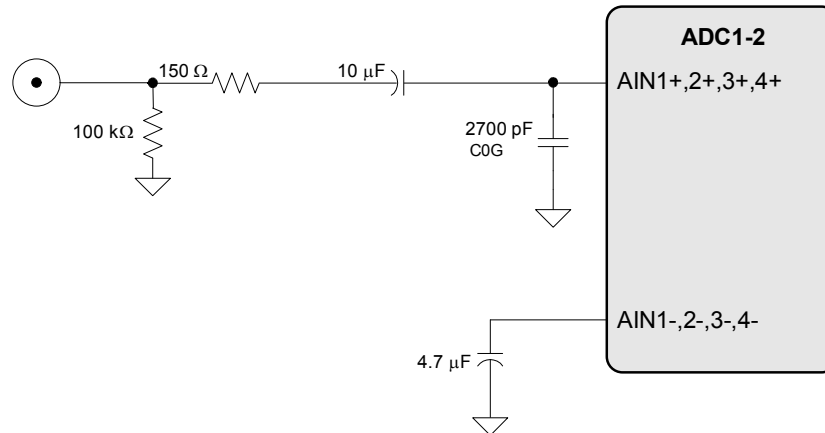


**Figure 20. Single-Ended Active Input Filter**



### 8.1.1 Passive Input Filter

The passive filter implementation shown in Figure 21 will attenuate any noise energy at 6.144 MHz but will not provide optimum source impedance for the ADC modulators. Full analog performance will therefore not be realized using a passive filter. Figure 21 illustrates the unity gain, passive input filter solution. In this topology the distortion performance is affected, but the dynamic range performance is not limited.

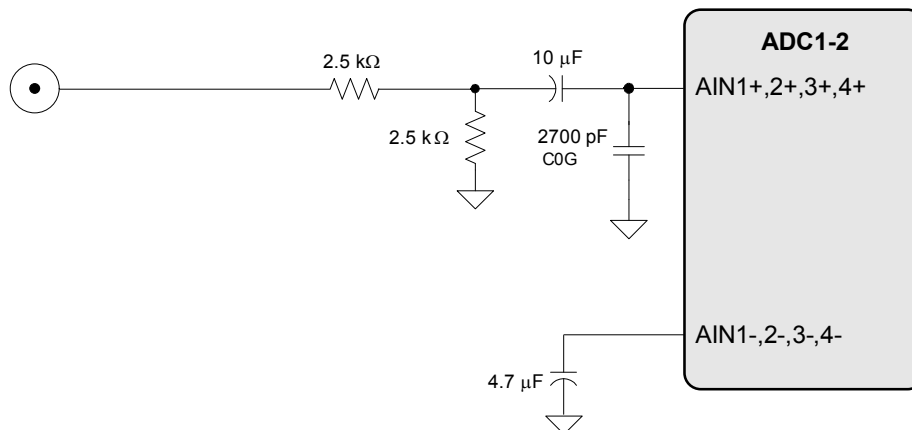


**Figure 21. Passive Input Filter**

### 8.1.2 Passive Input Filter w/Attenuation

Some applications may require signal attenuation prior to the ADC. The full-scale input voltage will scale with the analog power supply voltage. For  $V_A = 5.0\text{ V}$ , the full-scale input voltage is approximately 2.8 Vpp, or 1 Vrms (most consumer audio line-level outputs range from 1.5 to 2 Vrms).

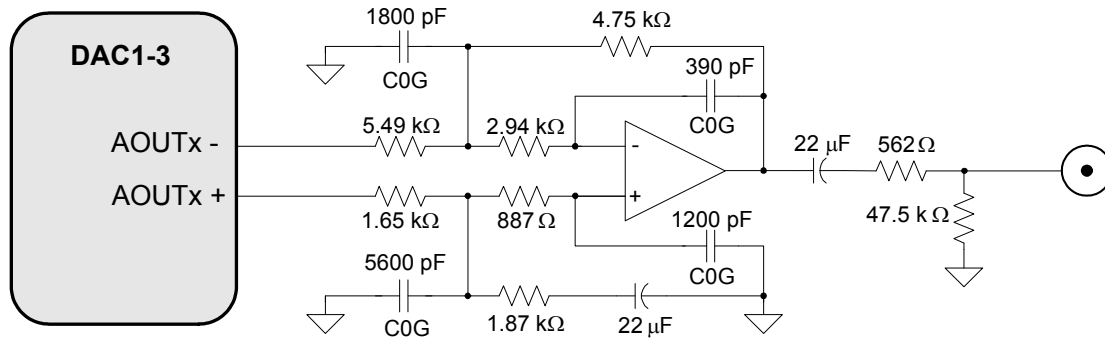
Figure 22 shows a passive input filter with 6 dB of signal attenuation. Due to the relatively high input impedance on the analog inputs, the full distortion performance cannot be realized. Also, the resistor divider circuit will determine the input impedance into the input filter. In the circuit shown in Figure 22, the input impedance is approximately 5 kΩ. By doubling the resistor values, the input impedance will increase to 10 kΩ. However, in this case the distortion performance will drop due to the increase in series resistance on the analog inputs.



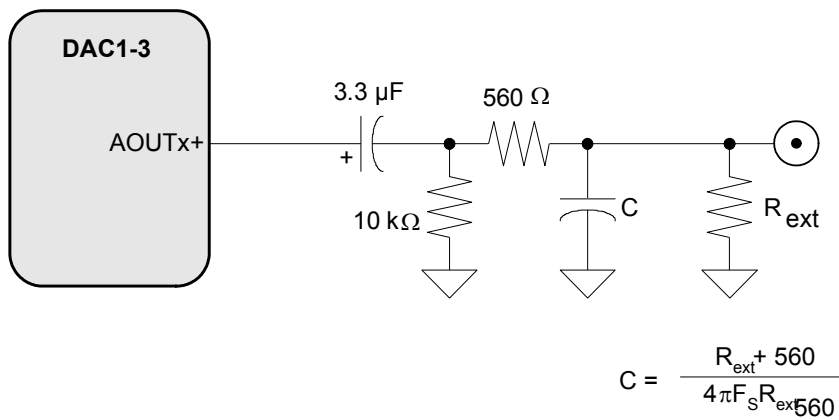
**Figure 22. Passive Input Filter w/Attenuation**

## 8.2 DAC Output Filter

The recommended active and passive output filters are shown below.

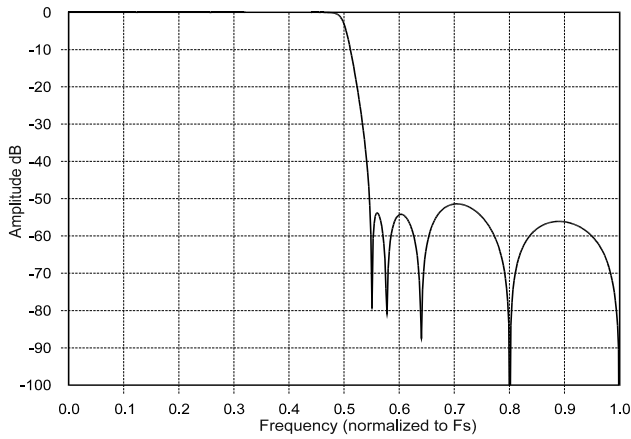


**Figure 23. Active Analog Output Filter**

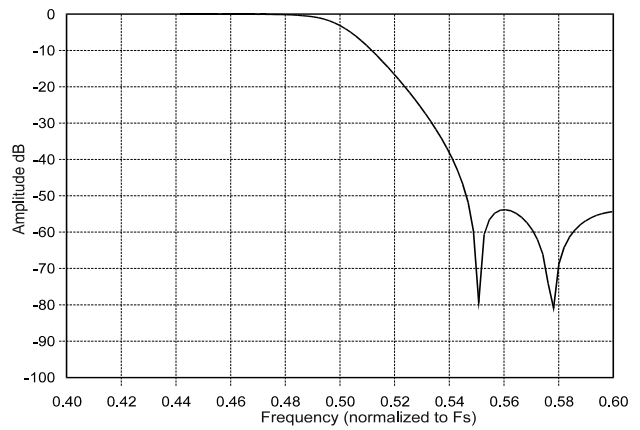


**Figure 24. Passive Analog Output Filter**

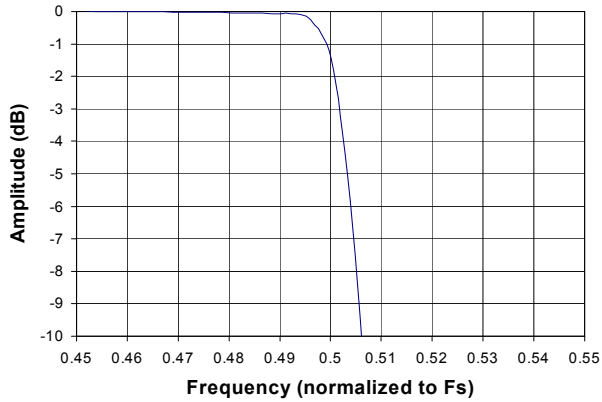
## 9. ADC FILTER PLOTS



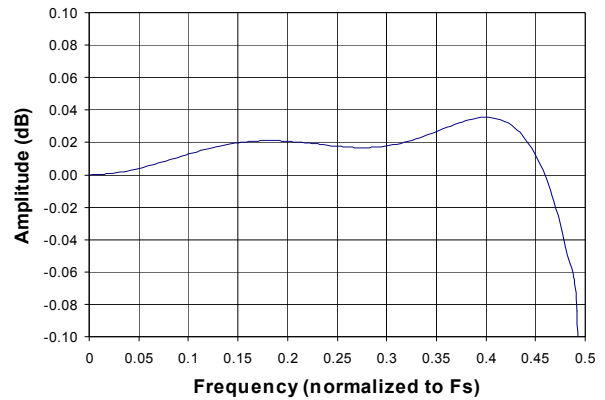
**Figure 25. SSM Stopband Rejection**



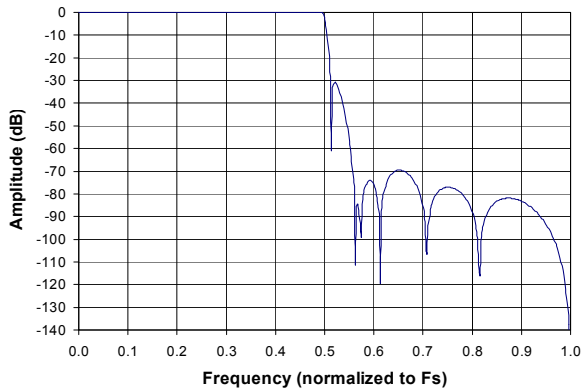
**Figure 26. SSM Transition Band**



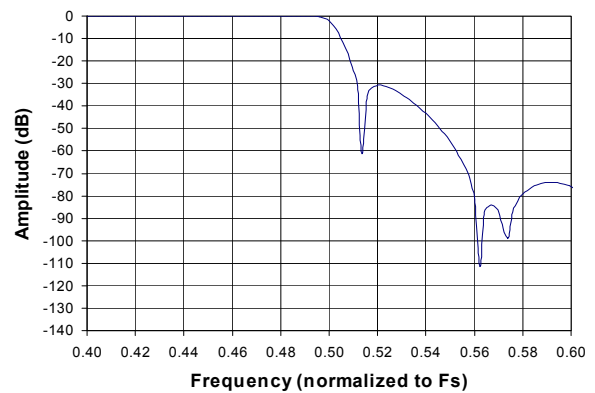
**Figure 27. SSM Transition Band (Detail)**



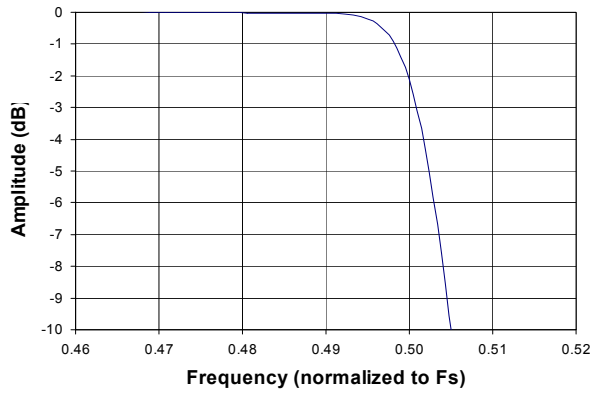
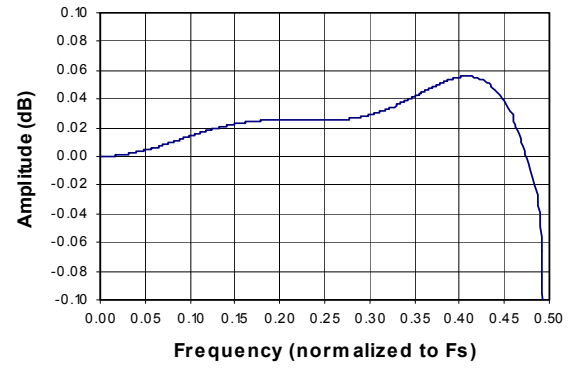
**Figure 28. SSM Passband Ripple**



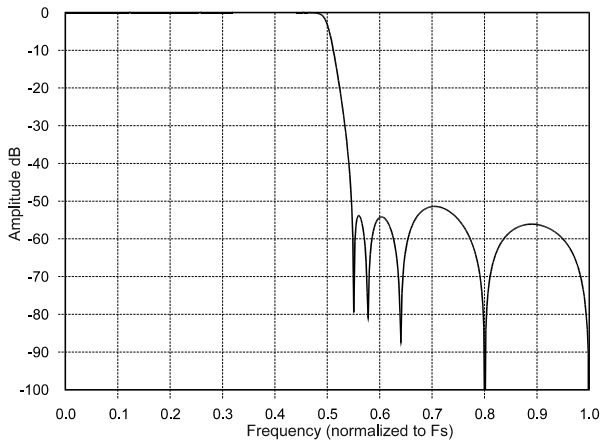
**Figure 29. DSM Stopband Rejection**



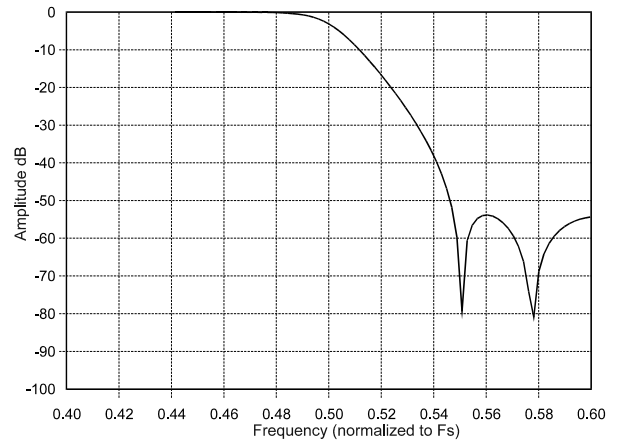
**Figure 30. DSM Transition Band**


**Figure 31. DSM Transition Band (Detail)**

**Figure 32. DSM Passband Ripple**

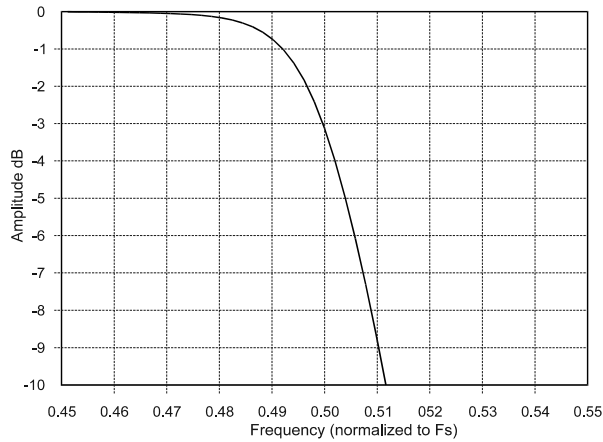
## 10.DAC FILTER PLOTS



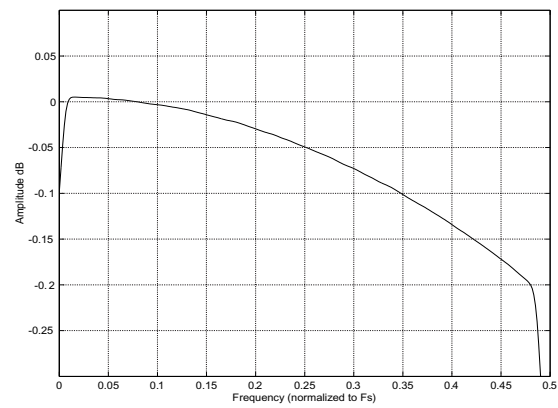
**Figure 33. SSM Stopband Rejection**



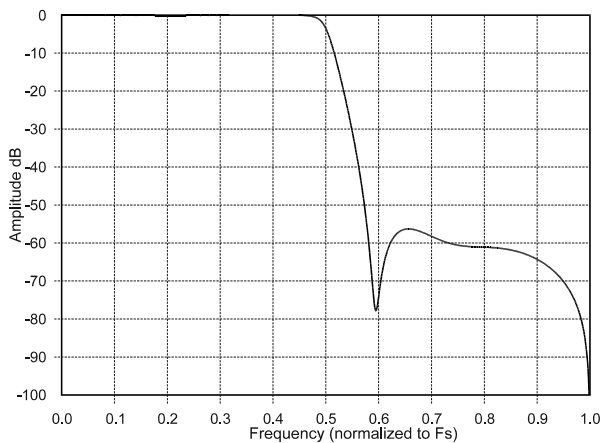
**Figure 34. SSM Transition Band**



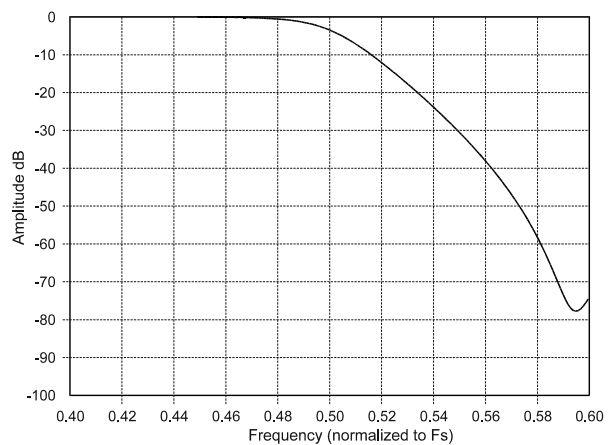
**Figure 35. SSM Transition Band (detail)**



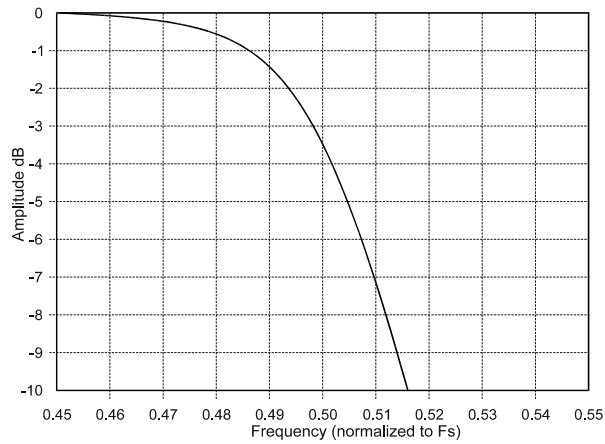
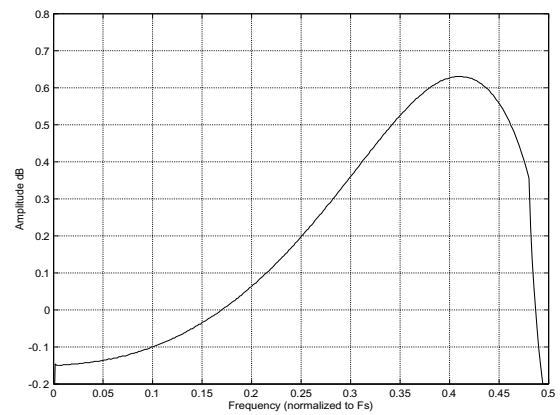
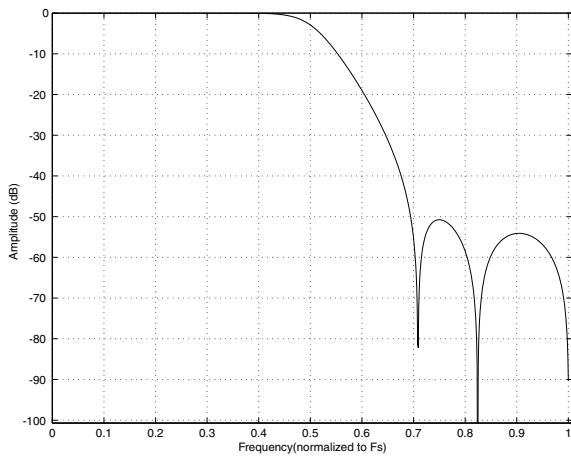
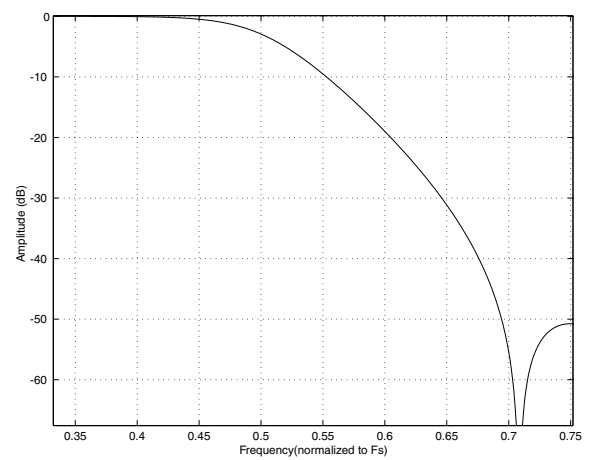
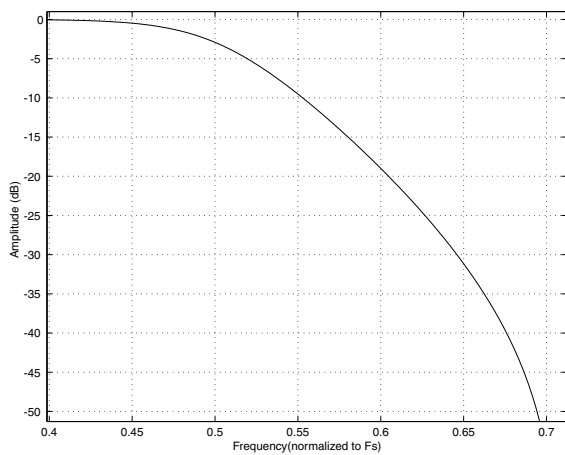
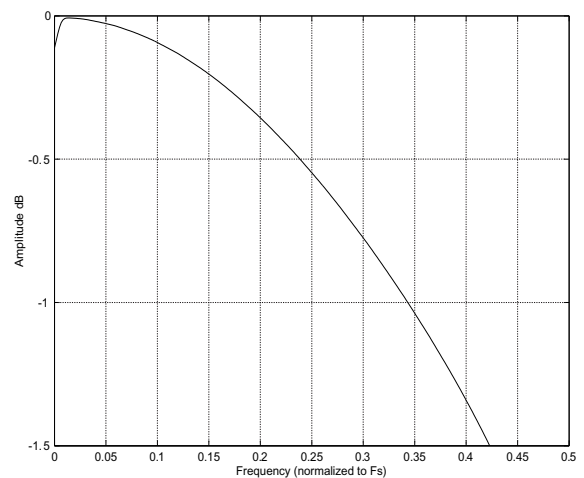
**Figure 36. SSM Passband Ripple**



**Figure 37. DSM Stopband Rejection**



**Figure 38. DSM Transition Band**


**Figure 39. DSM Transition Band (detail)**

**Figure 40. DSM Passband Ripple**

**Figure 41. QSM Stopband Rejection**

**Figure 42. QSM Transition Band**

**Figure 43. QSM Transition Band (detail)**

**Figure 44. QSM Passband Ripple**

---

## 11.PARAMETER DEFINITIONS

### Dynamic Range

The ratio of the rms value of the signal to the rms sum of all other spectral components over the specified bandwidth. Dynamic Range is a signal-to-noise ratio measurement over the specified band width made with a -60 dBFS signal. 60 dB is added to resulting measurement to refer the measurement to full-scale. This technique ensures that the distortion components are below the noise level and do not affect the measurement. This measurement technique has been accepted by the Audio Engineering Society, AES17-1991, and the Electronic Industries Association of Japan, EIAJ CP-307. Expressed in decibels.

### Total Harmonic Distortion + Noise

The ratio of the rms value of the signal to the rms sum of all other spectral components over the specified band width (typically 10 Hz to 20 kHz), including distortion components. Expressed in decibels. Measured at -1 and -20 dBFS as suggested in AES17-1991 Annex A.

### Frequency Response

A measure of the amplitude response variation from 10 Hz to 20 kHz relative to the amplitude response at 1 kHz. Units in decibels.

### Interchannel Isolation

A measure of crosstalk between the left and right channel pairs. Measured for each channel at the converter's output with no signal to the input under test and a full-scale signal applied to the other channel. Units in decibels.

### Interchannel Gain Mismatch

The gain difference between left and right channel pairs. Units in decibels.

### Gain Error

The deviation from the nominal full-scale analog output for a full-scale digital input.

### Gain Drift

The change in gain value with temperature. Units in ppm/°C.

### Offset Error

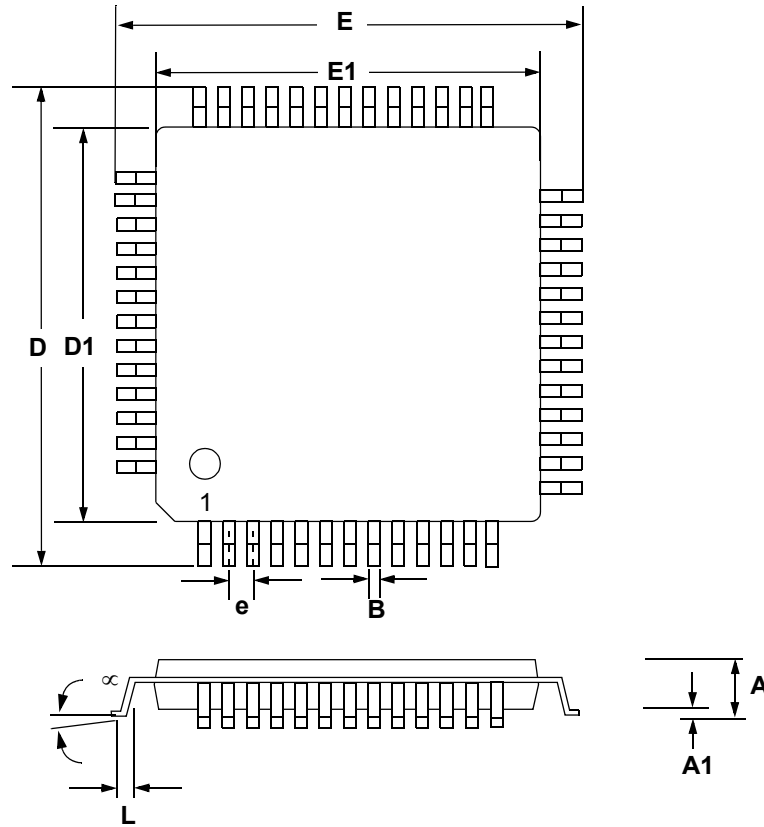
The deviation of the mid-scale transition (111...111 to 000...000) from the ideal. Units in mV.

---

## 12. REFERENCES

1. Cirrus Logic, *AN18: Layout and Design Rules for Data Converters and Other Mixed Signal Devices*, Version 6.0, February 1998.
2. Cirrus Logic, *Techniques to Measure and Maximize the Performance of a 120 dB, 96 kHz A/D Converter Integrated Circuit*, by Steven Harris, Steven Green and Ka Leung. Presented at the 103rd Convention of the Audio Engineering Society, September 1997.
3. Cirrus Logic, *A Stereo 16-bit Delta-Sigma A/D Converter for Digital Audio*, by D.R. Welland, B.P. Del Signore, E.J. Swanson, T. Tanaka, K. Hamashita, S. Hara, K. Takasuka. Paper presented at the 85th Convention of the Audio Engineering Society, November 1988.
4. Cirrus Logic, *The Effects of Sampling Clock Jitter on Nyquist Sampling Analog-to-Digital Converters, and on Oversampling Delta Sigma ADC's*, by Steven Harris. Paper presented at the 87th Convention of the Audio Engineering Society, October 1989.
5. Cirrus Logic, *An 18-Bit Dual-Channel Oversampling Delta-Sigma A/D Converter, with 19-Bit Mono Application Example*, by Clif Sanchez. Paper presented at the 87th Convention of the Audio Engineering Society, October 1989.
6. Cirrus Logic, *How to Achieve Optimum Performance from Delta-Sigma A/D and D/A Converters*, by Steven Harris. Presented at the 93rd Convention of the Audio Engineering Society, October 1992.
7. Cirrus Logic, *A Fifth-Order Delta-Sigma Modulator with 110 dB Audio Dynamic Range*, by I. Fujimori, K. Hamashita and E.J. Swanson. Paper presented at the 93rd Convention of the Audio Engineering Society, October 1992.
8. Philips Semiconductor, *The I<sup>2</sup>C-Bus Specification: Version 2.1*, January 2000.  
<http://www.semiconductors.philips.com>



**13.PACKAGE INFORMATION**
**52L MQFP PACKAGE DRAWING**


| DIM | INCHES |       |       | MILLIMETERS |           |       |
|-----|--------|-------|-------|-------------|-----------|-------|
|     | MIN    | NOM   | MAX   | MIN         | NOM       | MAX   |
| A   | ---    | ---   | 0.096 | ---         | ---       | 2.45  |
| A1  | 0.000  | ---   | 0.010 | 0.00        | ---       | 0.25  |
| B   | 0.009  | ---   | 0.016 | 0.22        | ---       | 0.40  |
| D   | ---    | 0.519 | ---   | ---         | 13.20 BSC | ---   |
| D1  | ---    | 0.394 | ---   | ---         | 10.00 BSC | ---   |
| E   | ---    | 0.519 | ---   | ---         | 13.20 BSC | ---   |
| E1  | ---    | 0.394 | ---   | ---         | 10.00 BSC | ---   |
| e*  | ---    | 0.026 | ---   | ---         | 0.65 BSC  | ---   |
| L   | 0.029  | 0.035 | 0.041 | 0.73        | 0.88      | 1.03  |
| ∞   | 0.00°  | 4°    | 7.00° | 0.00°       | 4°        | 7.00° |

\* Nominal pin pitch is 0.65 mm  
 Controlling dimension is mm.  
 JEDEC Designation: MS022

**13.1 Thermal Characteristics**

| Parameter                             |               | Symbol        | Min | Typ | Max | Units   |
|---------------------------------------|---------------|---------------|-----|-----|-----|---------|
| Junction to Ambient Thermal Impedance | 2 Layer Board | $\theta_{JA}$ | -   | 47  | -   | °C/Watt |
|                                       | 4 Layer Board | $\theta_{JA}$ | -   | 38  | -   | °C/Watt |

## 14. ORDERING INFORMATION

| Product  | Description                                    | Package  | Pb-Free | Grade      | Temp Range      | Container   | Order #      |
|----------|--|----------|---------|------------|-----------------|-------------|--------------|
| CS42432  | 4-in, 6-out, TDM CODEC for Surround Sound Apps | 52L-MQFP | YES     | Commercial | -10° to +70° C  | Rail        | CS42432-CMZ  |
|          |  |          |         |            |                 | Tape & Reel | CS42432-CMZR |
|          |  |          |         | Automotive | -40° to +105° C | Rail        | CS42432-DMZ  |
|          |  |          |         |            |                 | Tape & Reel | CS42432-DMZR |
| CDB42438 | CS42432 evaluation board                       | -        | -       | -          | -               | -           | CDB42438     |

## 15. REVISION HISTORY

| Revision | Changes  |
|----------|--|
| F1       | <ul style="list-style-type: none"> <li>Updated temperature and voltage specifications in the <a href="#">"Recommended Operating Conditions"</a> on page 13.</li> <li>Added test conditions to the Analog Input and Analog Output Characteristics tables.</li> </ul>  |
| F2       | <ul style="list-style-type: none"> <li>Updated input impedance specification for Differential and Single-Ended Inputs in <a href="#">"Analog Input Characteristics (Commercial)"</a> on page 14 and <a href="#">"Analog Input Characteristics (Automotive)"</a> on page 15.</li> <li>Updated <a href="#">"Pin Descriptions - Software Mode"</a> on page 6 to reflect correct placement of pins 3 and 4.</li> </ul>   |
| F3       | <ul style="list-style-type: none"> <li>Changed footnote 14 for <a href="#">Analog Output Characteristics (Automotive)</a> to <a href="#">One LSB of triangular PDF dither is added to data.</a></li> <li>Added VA = 3.3 V option to test conditions for <a href="#">Analog Input Characteristics (Commercial)</a>, <a href="#">Analog Input Characteristics (Automotive)</a>, <a href="#">Analog Output Characteristics (Commercial)</a>, and <a href="#">Analog Output Characteristics (Automotive)</a>.</li> <li>Updated Total Harmonic Distortion + Noise, single-ended maximum value in <a href="#">Analog Input Characteristics (Automotive)</a>.</li> <li>Updated Dynamic Range, 18 to 24-bit minimum values in <a href="#">Analog Output Characteristics (Automotive)</a>.</li> </ul> |
| F4       | <ul style="list-style-type: none"> <li>Updated MFreq2:0 == 001 and MFreq2:0 == 011 (ratios of 384x and 768x) to "Reserved" in <a href="#">Table 5</a>.</li> </ul>  |

## Contacting Cirrus Logic Support

For all product questions and inquiries, contact a Cirrus Logic Sales Representative.  
To find the one nearest you, go to [www.cirrus.com](http://www.cirrus.com).

### IMPORTANT NOTICE

Cirrus Logic, Inc. and its subsidiaries ("Cirrus") believe that the information contained in this document is accurate and reliable. However, the information is subject to change without notice and is provided "AS IS" without warranty of any kind (express or implied). Customers are advised to obtain the latest version of relevant information to verify, before placing orders, that information being relied on is current and complete. All products are sold subject to the terms and conditions of sale supplied at the time of order acknowledgment, including those pertaining to warranty, indemnification, and limitation of liability. No responsibility is assumed by Cirrus for the use of this information, including use of this information as the basis for manufacture or sale of any items, or for infringement of patents or other rights of third parties. This document is the property of Cirrus and by furnishing this information, Cirrus grants no license, express or implied under any patents, mask work rights, copyrights, trademarks, trade secrets or other intellectual property rights. Cirrus owns the copyrights associated with the information contained herein and gives consent for copies to be made of the information only for use within your organization with respect to Cirrus integrated circuits or other products of Cirrus. This consent does not extend to other copying such as copying for general distribution, advertising or promotional purposes, or for creating any work for resale.

CERTAIN APPLICATIONS USING SEMICONDUCTOR PRODUCTS MAY INVOLVE POTENTIAL RISKS OF DEATH, PERSONAL INJURY, OR SEVERE PROPERTY OR ENVIRONMENTAL DAMAGE ("CRITICAL APPLICATIONS"). CIRRUS PRODUCTS ARE NOT DESIGNED, AUTHORIZED OR WARRANTED FOR USE IN PRODUCTS SURGICALLY IMPLANTED INTO THE BODY, AUTOMOTIVE SAFETY OR SECURITY DEVICES, LIFE SUPPORT PRODUCTS OR OTHER CRITICAL APPLICATIONS. INCLUSION OF CIRRUS PRODUCTS IN SUCH APPLICATIONS IS UNDERSTOOD TO BE FULLY AT THE CUSTOMER'S RISK AND CIRRUS DISCLAIMS AND MAKES NO WARRANTY, EXPRESS, STATUTORY OR IMPLIED, INCLUDING THE IMPLIED WARRANTIES OF MERCHANTABILITY AND FITNESS FOR PARTICULAR PURPOSE, WITH REGARD TO ANY CIRRUS PRODUCT THAT IS USED IN SUCH A MANNER. IF THE CUSTOMER OR CUSTOMER'S CUSTOMER USES OR PERMITS THE USE OF CIRRUS PRODUCTS IN CRITICAL APPLICATIONS, CUSTOMER AGREES, BY SUCH USE, TO FULLY INDEMNIFY CIRRUS, ITS OFFICERS, DIRECTORS, EMPLOYEES, DISTRIBUTORS AND OTHER AGENTS FROM ANY AND ALL LIABILITY, INCLUDING ATTORNEYS' FEES AND COSTS, THAT MAY RESULT FROM OR ARISE IN CONNECTION WITH THESE USES.

Cirrus Logic, Cirrus, and the Cirrus Logic logo designs are trademarks of Cirrus Logic, Inc. All other brand and product names in this document may be trademarks or service marks of their respective owners.

°C is a trademark of Philips Semiconductor.

SPI is a trademark of Motorola, Inc.